

LOUISIANA STATE UNIVERSITY

DESIGN GUIDELINES

SEPTEMBER 2017

LSU



LSU DESIGN GUIDELINES

DESIGN GUIDELINES TABLE OF CONTENTS

1.1 FOREWORD

- Purpose
- Mission + Core Ideas

1.2 LENSES OF ANALYSIS

- History of Campus Development
- Program Response
- Proximity to the Core
- Topography and Landscape

1.3 CHARACTER STUDIES

- Character Typologies
- Representative Buildings

1.4 DESIGN PRINCIPLES

- Guiding Narrative
- Design Principles

1.5 SUSTAINABILITY

- Letter from Campus Sustainability
- Performance Requirements
- CCS Integration

1.6 GOVERNANCE

- Key Components
- Key Players
- Process and Criteria

MASTER PLAN

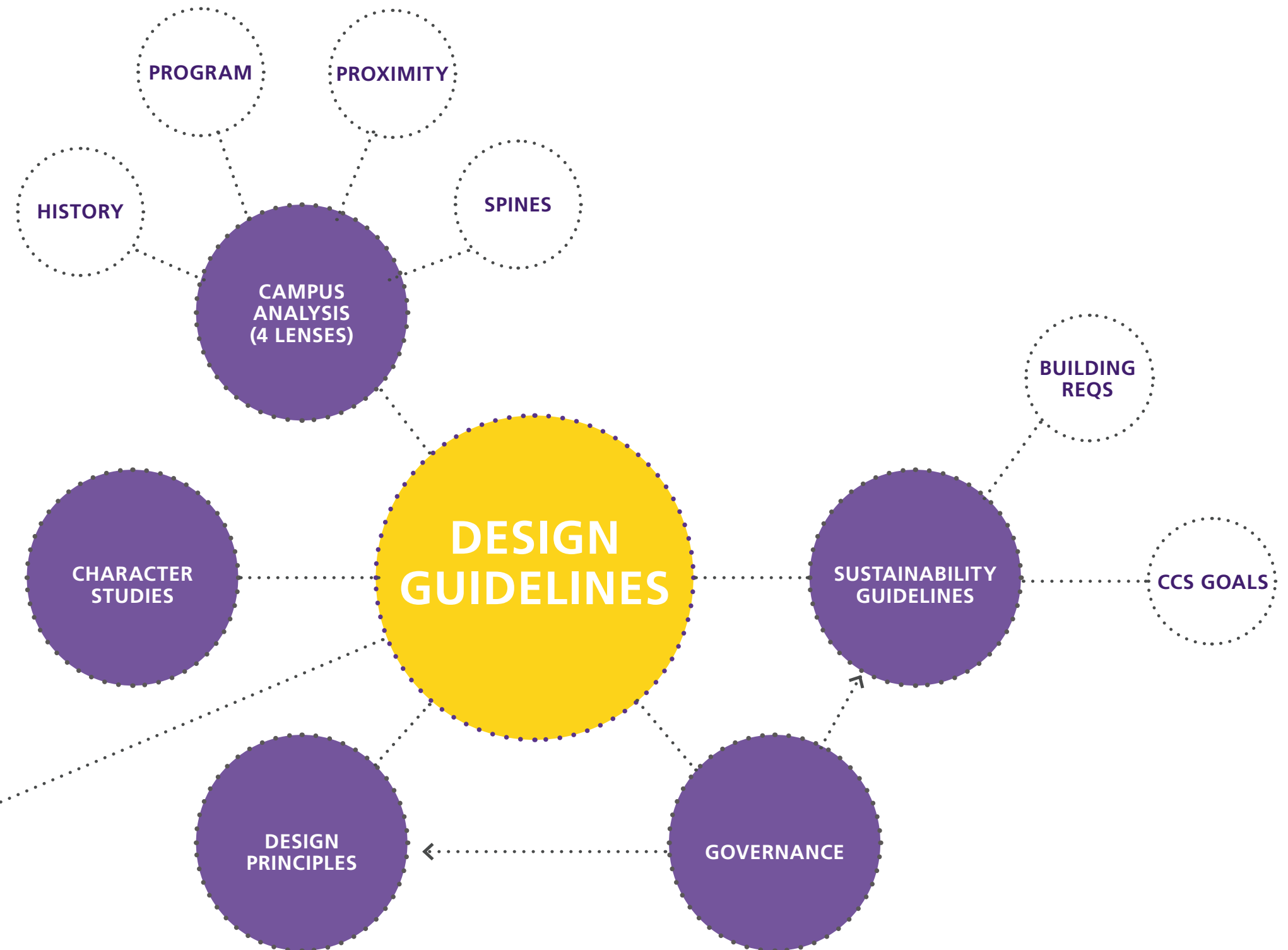

DESIGN GUIDELINES

1.1 FOREWORD

PURPOSE

During a noteworthy exchange between our Master Plan Design Team and a prominent member of the LSU Board of Supervisors, the question was posited to the design team: “**Why LSU?**”.

Why, he asked, will students continue to seek an education at our prestigious university (or any other university, for that matter) in the decades to come, given the increasingly easy access to online programs and virtual classroom opportunities? If academic instruction is at the heart of the higher education experience, isn't there a much more straightforward approach to learning than attending a university? The question cut to the heart of the matter, a fundamental issue which required a deeper understanding of the complex motivations and aspirations of today's young adults.

The answer, I believe, is that in addition to formal learning, our university offers students a collection of **memorable experiences** which cannot be obtained in a “virtual” academic setting. Shared moments and intimate experiences, celebrations and traditions, rituals and spontaneous happenings, history and legacy, are all intertwined to create a collective experience adding richness, vitality and depth of meaning. And central to any experience is its setting, often in a memorable place – sometimes a quiet place, a place of reflection, such as the Greek Theater. Or an intimate place, shaded by oaks and nestled below an arcade. Or a public place, open to the summer sun and throngs of students.

As such, campus design is first and foremost about **memorable placemaking**, and in virtually every case, placemaking stems from the **seamless integration of architecture and landscape**. And on the LSU campus, it has been so from the start. The first designer to set foot on the soil which was to become the LSU campus was a landscape architect, not an architect. From the start, the campus was conceived as a response to the unique aspects of the local topography, landscape and climate. The noteworthy topographic condition, the relationship of the elevated highland bluff to the lowland and river, was accentuated and celebrated in the concept design, as was the sensitive response to the clusters of mature oak trees and historic Indian mounds. And acknowledging the hot-humid climate of the region, the designers established an architectural character based on the similar architectural response to the climatic conditions of Mediterranean Europe. Rather than arbitrary design choices, these were sensitive, **authentic responses** rooted in the fundamental nature of this unique place, resulting in a truly timeless design.

Even the LSU Alma Mater acknowledges this intimate relationship between building and landscape: “Where stately oaks and broad magnolias shade inspiring halls...”

So our foundation is set, and we move forward. Each designer assigned to a new project is challenged to create authentic design responses that are of both their time and their place, embedded in the historic fabric of the campus while simultaneously reflecting a future-forward, 21st century vision of academic experience. These Design Guidelines are intended to assist designers in that regard, offering lenses by which the designer may observe the conditions and opportunities in perhaps a different manner, and develop sensitive, timeless responses. As such, the designers have the opportunity to extend and enhance the rich design legacy of the LSU campus for many years to come.

- Mark Ripple, FAIA
Eskew Dumez Ripple
04 August 2017

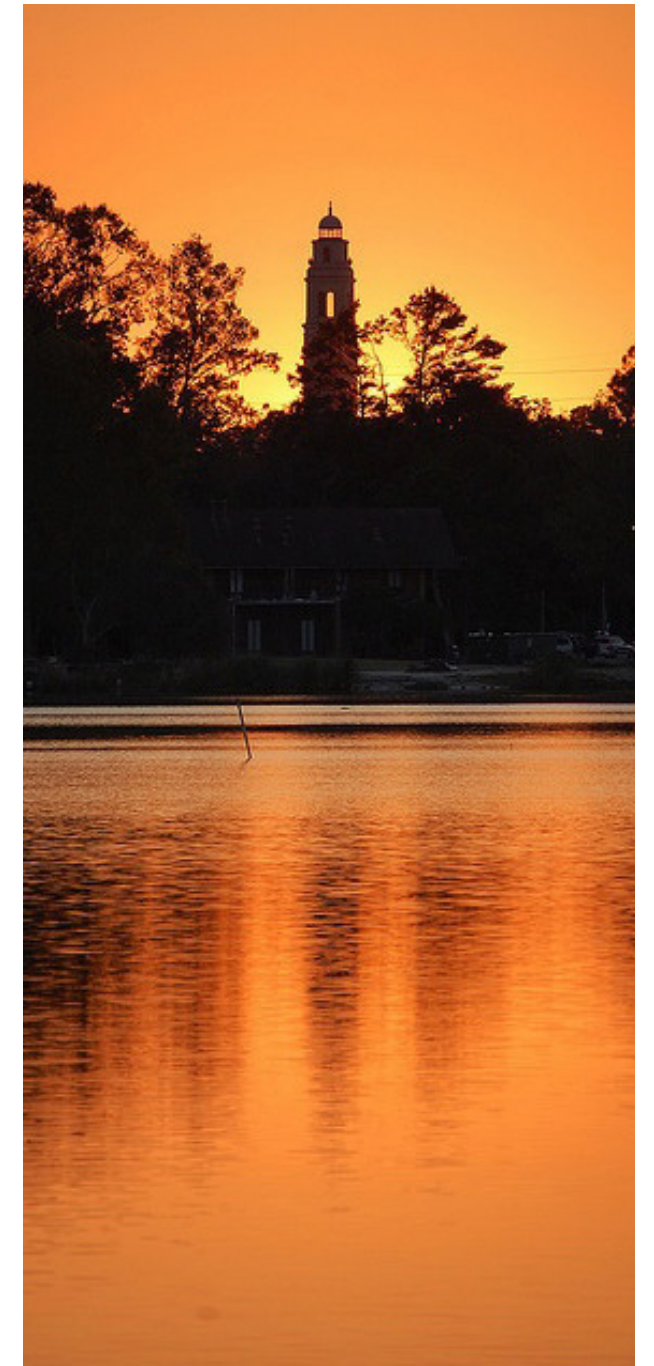

DESIGN GUIDELINES

1.1 FOREWORD

MISSION + CORE IDEAS

MASTER PLAN MISSION STATEMENT “Respecting the culture, **heritage** and diversity of Louisiana State University, this Comprehensive and Strategic Master Plan will provide a **flexible framework** that sustainably guides and **integrates development** and capital investment on the campus and in the community over the next decade and beyond. The Master Plan will support LSU’s Flagship designation and will reinforce its status as a high-performance, **contemporary**, research and **living/learning environment** the Flagship of Flagship Universities.”

RESPECTING HERITAGE: The aesthetic quality and character of the LSU campus is a cherished and highly valued resource, defined by the beautiful integration of its historic architectural context and its rich, mature landscape. Designers should respect this architectural heritage by understanding the underlying principles of the historic campus design, and utilizing those principles in the design of new buildings and places.

INTEGRATED DEVELOPMENT: LSU’s historic focus buildings, such as the Memorial Tower and the Law Library, create nodes at the terminus of formally organized social space, and are knitted together by buildings that create a walkable, human-scale fabric. The South Academic District, by contrast, has evolved more episodically, and its buildings are seen as stand-alone focal elements rather than contributions to overall campus fabric. It is the intent of these guidelines to focus future development toward establishing a cohesive, walkable, and human-scale fabric that transforms disconnected areas into a more cohesive, beautiful environment.

FLEXIBLE FRAMEWORK: A beautiful campus develops incrementally, at times following a clear, ordered vision and at times evolving organically. Designers are challenged to design buildings to last a half-century or more, based on programmatic needs that change often and in unexpected ways. The design guidelines are written in such a way as to allow designers to meet these goals while optimizing flexibility to adapt to changes in pedagogy over time.

LIVING/LEARNING ENVIRONMENT: LSU is a Flagship University that embraces a future-forward vision of 21st century pedagogy, technology and social interaction. As a forward-thinking institution of higher learning, it should build on its past but look to the future in terms of teaching research, responding to current and future needs; and its architecture and environment should reflect that attitude. As J.J. Earley envisioned, the campus should be “an intuitive course in architecture for the students.” (*The Architecture of LSU*, J. Michael Desmond, pg. 56). Campus and building design can be an extremely useful pedagogical tool, clearly communicating to students and faculty the subtle balance between historic context and contemporary academic vision.

DESIGN GUIDELINES

1.2 LENSES OF ANALYSIS

The following four Lenses of Analysis are a means by which to **establish a campus-scaled framework** by which specific design projects can be viewed. The LSU campus spans over 1,200 acres, over 500 buildings, and nearly 100 years. As such, appropriate design responses will vary greatly across the campus and across time.

The way in which a building responds to the principle of human scale, for example, can and should **vary depending upon location, time, and programmatic needs**. Take the original Tiger Stadium and Hill Memorial Library- they are both successful examples of contextual responses to program and site. Tiger Stadium is intended to inspire school spirit and recognize the grandeur of sport. As such, Tiger Stadium is a monumental structure which is experienced at a monumental scale. Hill Memorial Library, on the other hand, is a place of reflection and academic engagement, requiring an architectural response at the scale of the human body and with careful detail in mind.

The first of the following lenses asks designers to understand their place in history as well as the forces that created the campus. Lens two encourages special consideration be made with regard to collective groupings of similar program across the campus. Lens three reminds designers of the lasting influence of the campus's historic core, and its influence on future development. Lastly, the fourth lens emphasizes the understanding of landscape and topography in the placement of new buildings on campus.

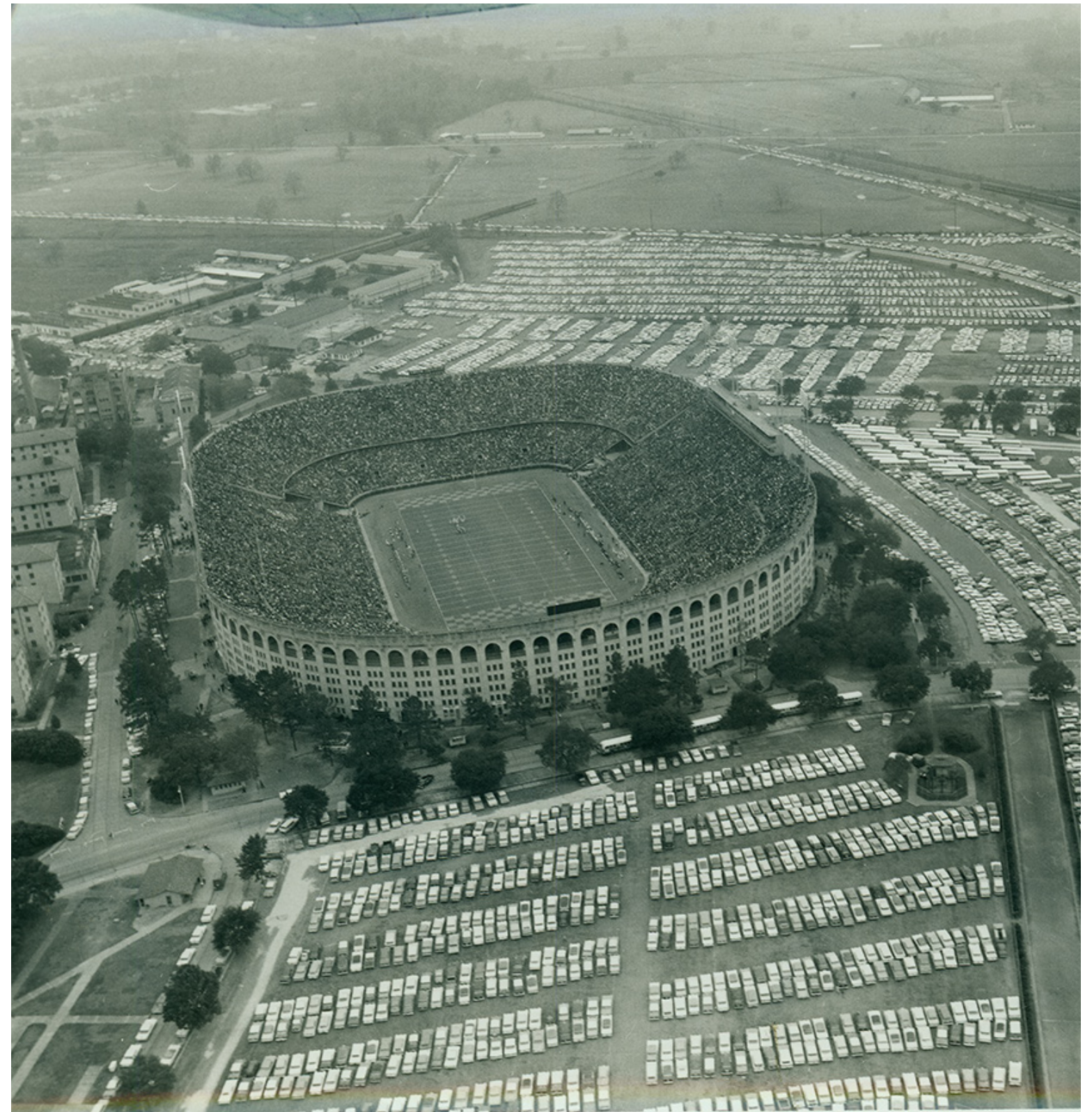

DESIGN GUIDELINES

LENS 1: HISTORY OF CAMPUS DEVELOPMENT

GROWTH MILESTONES

Despite wide stylistic and programmatic considerations, buildings and landscapes at LSU will always share the same collective history. As new buildings and places are developed on campus, they too become part of this collective history. The manner in which the campus has grown over the last century will inform the growth of the next century.



The LSU campus began with the purchase of the Gartness and Nestle Down Plantations. The property included lowland and upland fields. The two areas were separated by a distinct river escarpment landform, which informed the siting of the first campus buildings on the 'high ground'.



Campus growth initially moved in eastward along the upland areas, encouraged in part by the creation of the Baton Rouge Lakes. By the 1970s growth was occurring to the west into the lowland areas. These buildings were often sited without regard for the escarpment, instead conforming to road alignments or the availability of space.



PRESENT AND FUTURE PLANNING

Planning for the campus beyond 2017 envisions continued growth to the south and west, with a new academic quad developing around Patrick F. Taylor Hall and the Energy, Coast and Environment building. This shifting center of campus will be anchored by a new Learning Center and a restoration of campus linkages along the escarpment to connect the historic campus core with the developing South Campus and Athletics campus districts. Investment in the continued rehabilitation of the original buildings, quads, and canopies will ensure the unique character of LSU's campus is preserved for future generations of students.

DESIGN GUIDELINES

LENS 1: HISTORY OF CAMPUS DEVELOPMENT

DEVELOPMENT BY DECADE

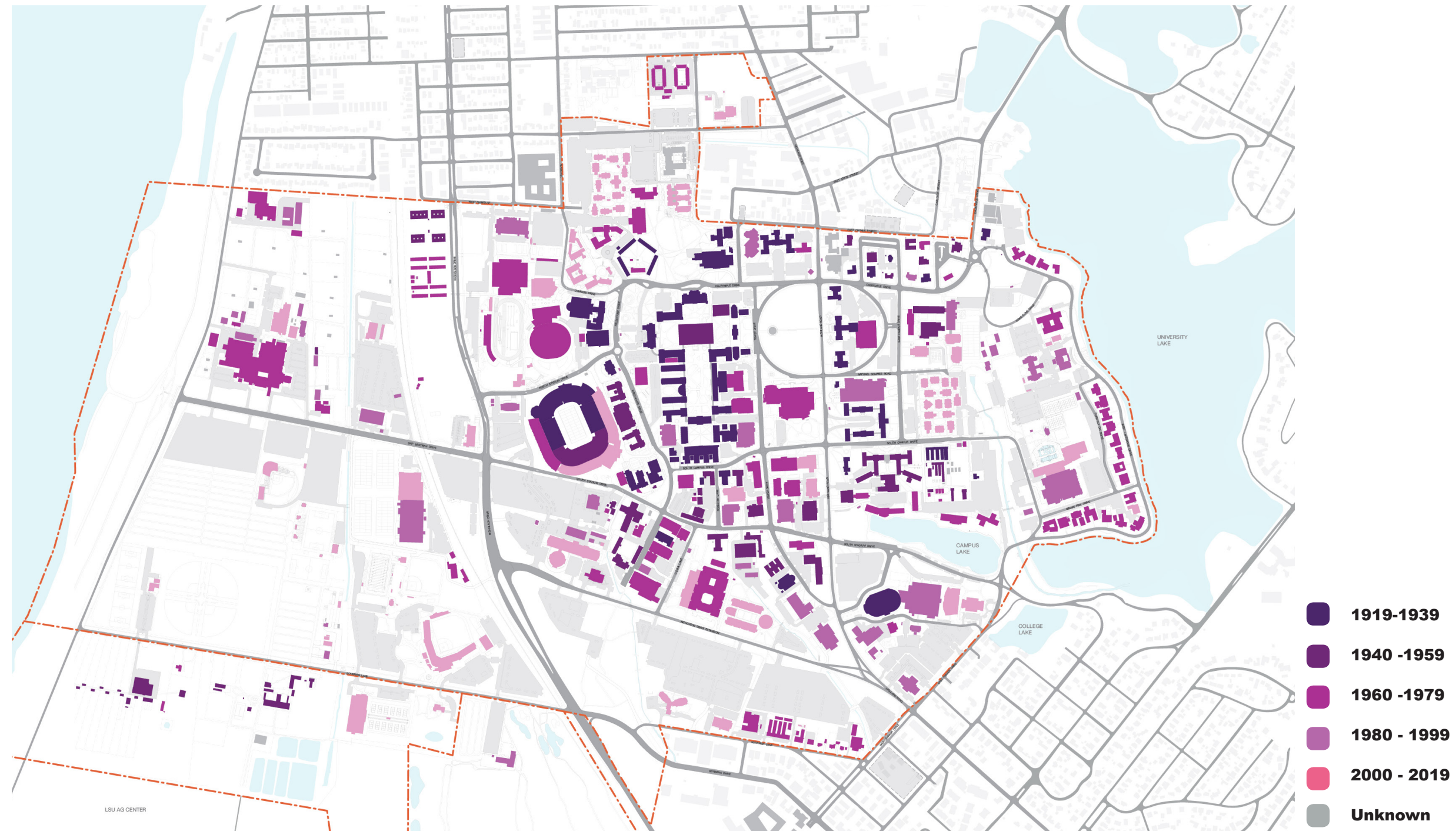

DESIGN GUIDELINES

LENS 1: HISTORY OF CAMPUS DEVELOPMENT

“FABRIC” AND “FOCUS” BUILDINGS

The original campus design envisioned certain buildings to be “focal” elements of the campus, by virtue of their prominent location as well as their functional and symbolic importance. All other buildings were designed to contribute to the overall “fabric” of the campus, creating a contextual backdrop for the focal structures.



Atkinson Hall



Hill Memorial Library

Notably, there are only two buildings on campus which include tower elements in their design: the Memorial Tower and Atkinson Hall. As two of the seven existing “focus buildings” on the campus, they are notable due to their prominent location, their capacity to embody the university and represent its core values, and their importance as wayfinding landmarks.









Memorial Tower and Law Center Buildings

DESIGN GUIDELINES

LENS 1: HISTORY OF CAMPUS DEVELOPMENT

HISTORIC DESIGNATION

Several of the buildings on campus have been designated historic structures under the National Register of Historic Buildings. These buildings form the historic basis of the architectural character of LSU. Additionally, several buildings contribute to the historic character of the campus, but are not currently listed on the Historic Register.

-  Focus Building
-  Focus Sites
-  Buildings on the National Historic Register
-  LSU Historic Buildings- not on Historic Register
-  Existing Fabric Buildings
-  Proposed Fabric Buildings



DESIGN GUIDELINES

LENS 2: PROGRAM RESPONSE

LSU IS AN ECLECTIC AND “OVERLAPPING” CAMPUS, BUT IS BROADLY BROKEN DOWN INTO THREE PROGRAM AREAS: PLAY, LEARN, LIVE.

PLAY A large number of visitors encounter LSU through its athletic programming; athletic buildings and associated outdoor spaces should be flag bearers of the university’s unique architectural identity. Large parking lots are common in this district, and new designs should be flexible for diverse uses, in order to integrate with stormwater management and to enhance the tailgating experience. Designers should **provide pedestrian-oriented connections that mitigate the district’s expansive scale** and respond to the multi-modal Nicholson Spine with bike infrastructure and comfortable places to wait for transit.

LEARN The historic academic quadrangle is the heart of campus, and many of the principles in this document are derived from it. The South Academic District (south campus) is the University’s primary growth vector, and represents its greatest opportunity to incorporate **sustainable design**. Buildings in this district should reflect the University’s “future forward” vision of contemporary academics, while respecting and augmenting the fabric of development that has served the university well in the historic core. When incorporating social spaces in these districts, **design for a broad range of academic and social activities**.

LIVE Connect residence halls to the parking that serves them and the rest of campus through safe, attractive, pedestrian thoroughfares that celebrate the landscape, especially the lake and Corporation Canal. This district should feel safe, territorialized, residential in scale, and provide a sense of home. Social spaces in and around residences should **invite casual interaction and recreation**, and incorporate smaller, buffered green space for quiet, focused experiences.

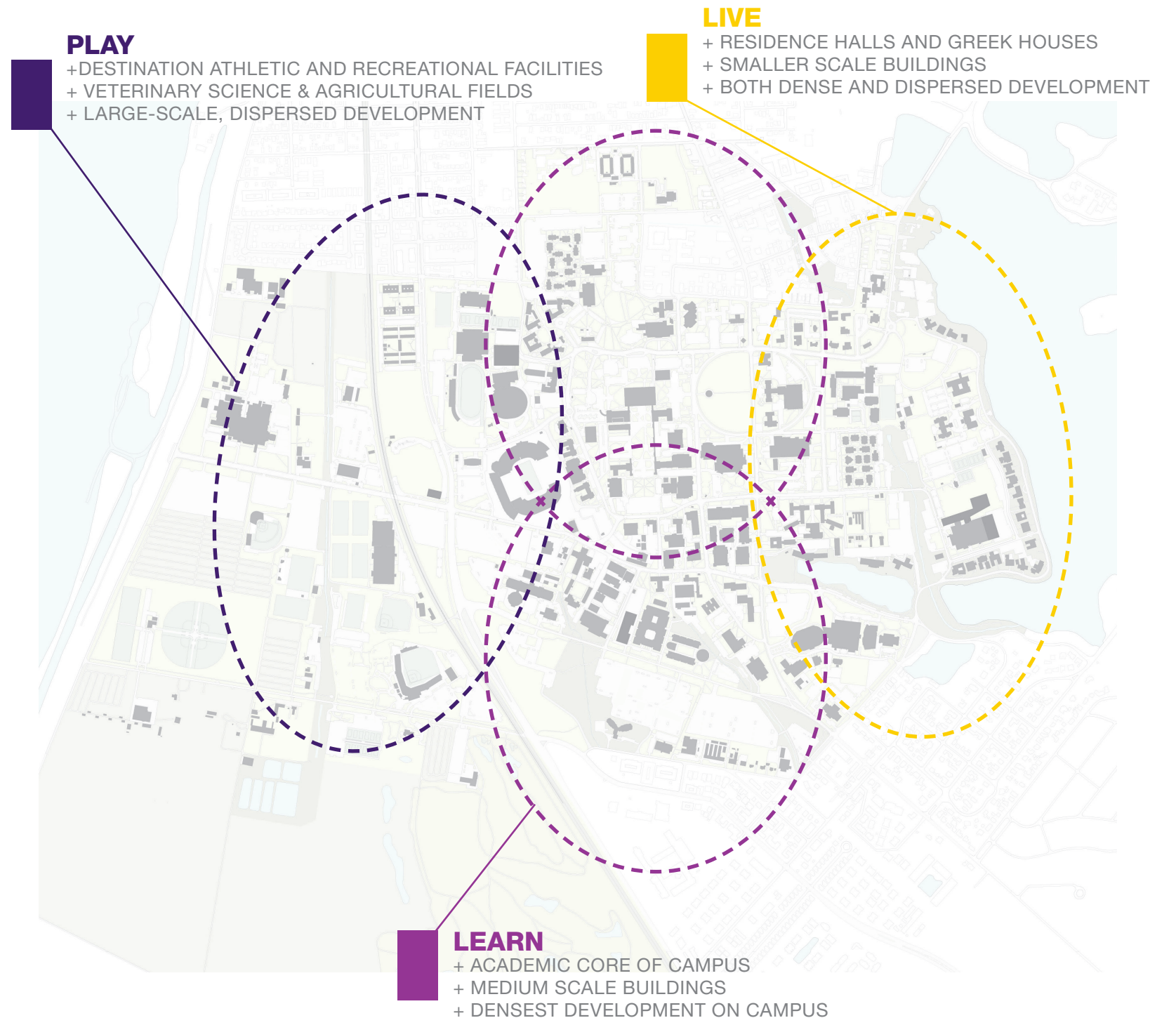

DESIGN GUIDELINES

LENS 2: PROGRAM RESPONSE

ARCHITECTURAL DESIGN OFTEN REFLECTS “SERVED” AND “SERVANT” SPACES

The architecture of the original campus acknowledged the distinct difference between “served” and “servant” buildings. Academic and administrative buildings were generally clad in more upscale materials, including small-aggregate concrete and plaster, and often included neoclassical detailing and trim. Conversely, the more utilitarian structures were often clad in locally-obtained brick, and were more austere in appearance.

While such formal distinctions have dissolved to a large degree in the last fifty years, it is important to acknowledge the degree to which new structures might respond to unique programmatic requirements, while still respectful of the overall campus context.



DESIGN GUIDELINES

LENS 3: PROXIMITY TO THE CORE

INFLUENCE OF THE HISTORIC CORE ON NEW ARCHITECTURE

The architectural character of the campus has been shaped by the development of the historic academic core in the first three decades of the 20th century. Arguably, the “influence” of this architectural character and formal organizational logic diminishes with physical distance from the core. The focus of future development in the South Academic District affords the opportunity to develop a coherent architectural character reflecting 21st century academic vision, in much the same way that the historic core reflected 20th century academic vision.

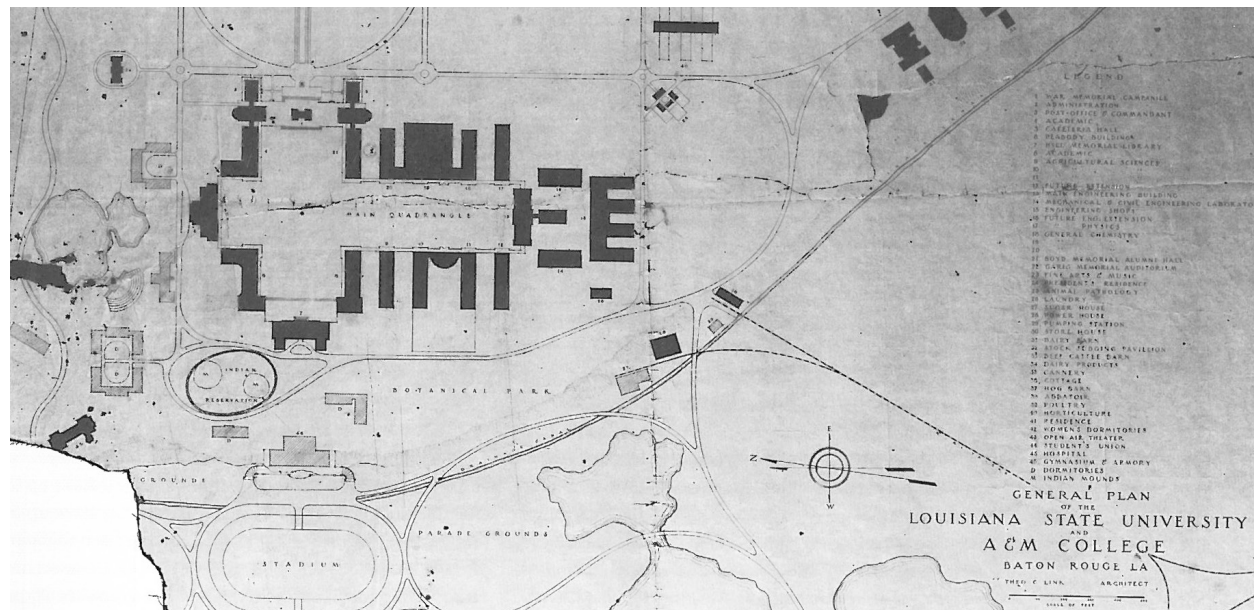

“Link’s plan was one in which the role of buildings as carriers of meaning was strengthened, even displacing the perception of patterns in the landscape.”

- J. Michael Desmond, The Architecture of LSU

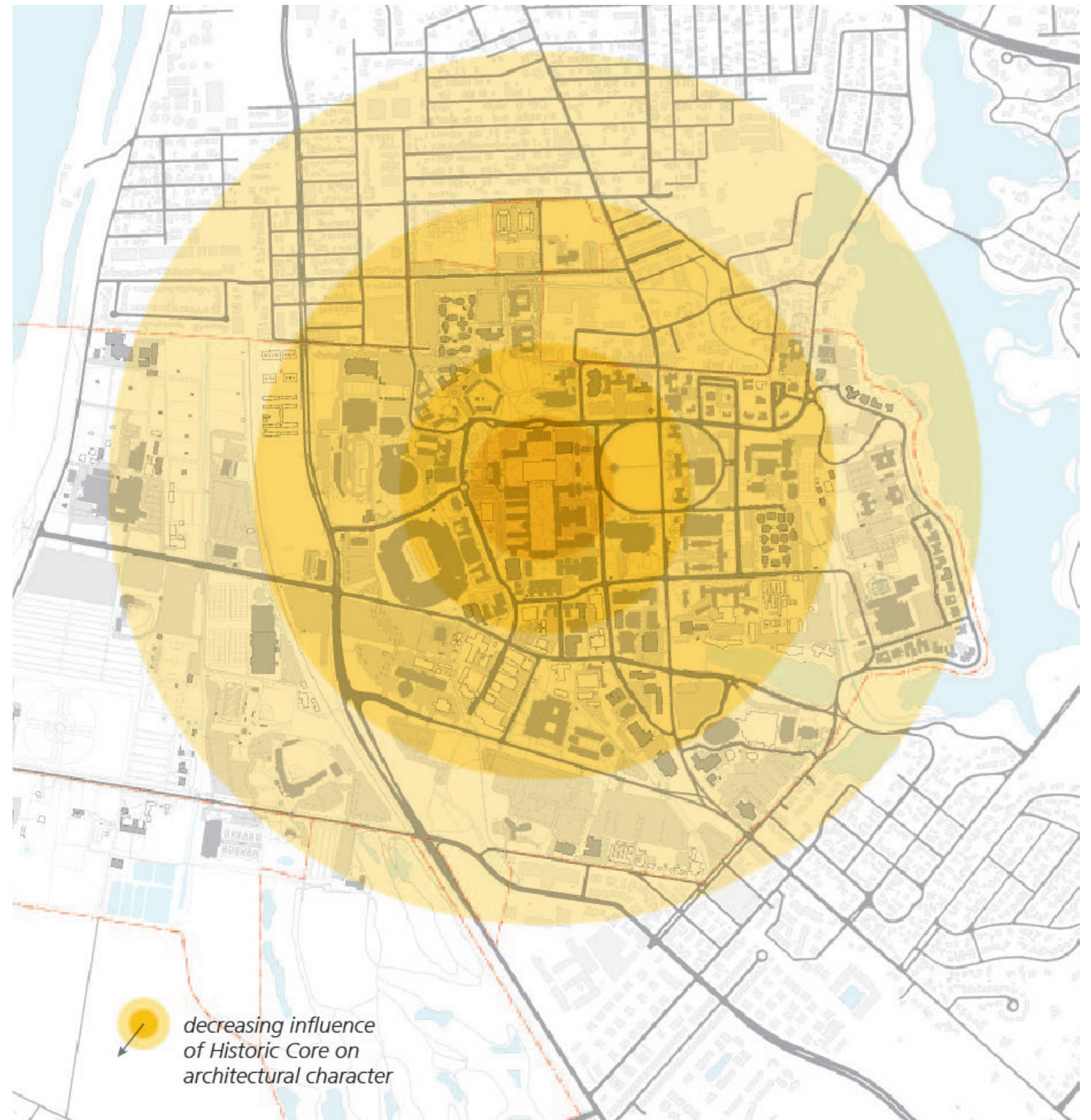

DESIGN GUIDELINES

LENS 4: TOPOGRAPHY AND LANDSCAPE

RESPONSE TO CONTEXT

The campus design was originally conceived as a response to the unique aspects of the local landscape, topography and climate. The relationship of the elevated highland bluff to the lowland and river was accentuated in the master plan, as was the sensitive response to the clusters of mature oak trees and historic Indian mounds.



The Master Plan aspires to reinforce the importance of the north-south pedestrian circulation spines which exist across the campus. New building projects should be sited and oriented in a manner which reinforces the spines as a central campus organizing element.

DESIGN GUIDELINES

1.3 CHARACTER STUDIES

CHARACTER TYPOLOGIES

HISTORIC CORE

- Atkinson Hall

CONTRIBUTING STRUCTURE

- Gym Armory

CONTEMPORARY - LITERAL

- Emerging Technology Center

CONTEMPORARY - INTERPRETIVE

- Student Union

CONTEMPORARY - NON-REFERENTIAL

- School of Veterinary Medicine

NON-CONTRIBUTING

The following is a collection of architectural character studies. For landscape character studies, see the Campus Landscape & Site Design Standards 2017.



DESIGN GUIDELINES

CHARACTER TYPOLOGIES

While no taxonomy is indeed perfect, it is often useful to categorize the range of buildings on the campus, in order to understand overall context.

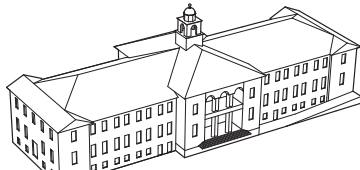
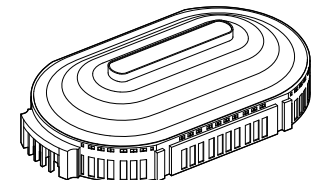
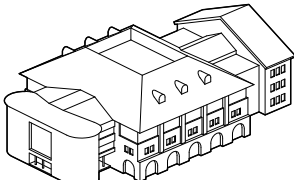
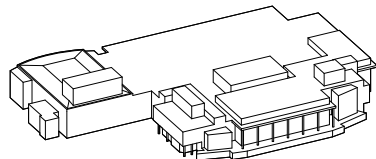
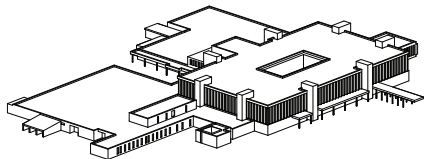
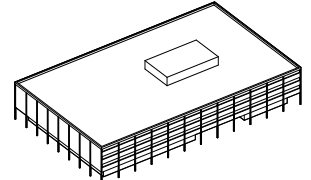
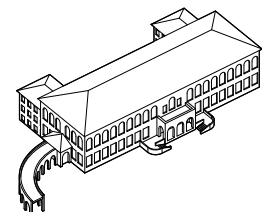
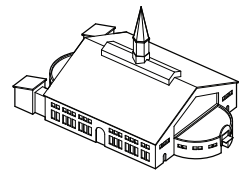
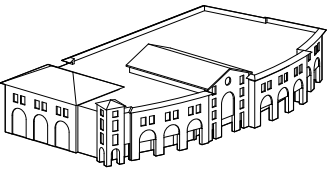
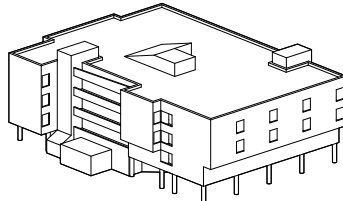
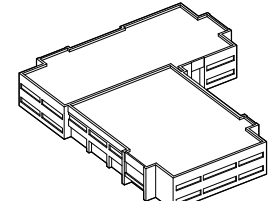
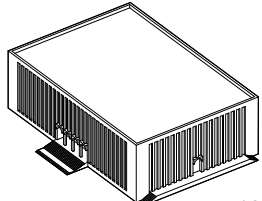
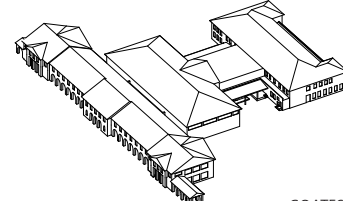
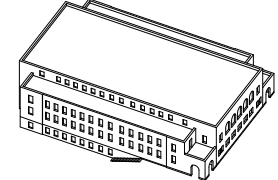
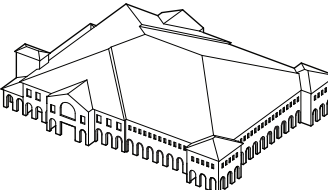
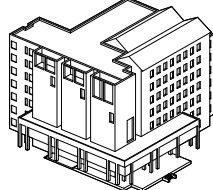
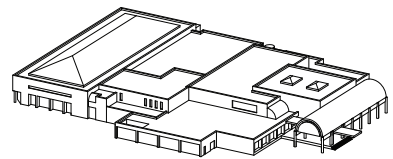
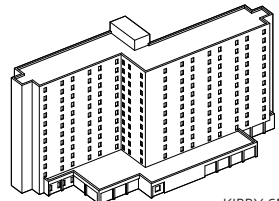
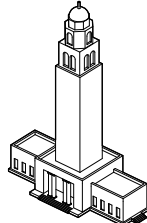
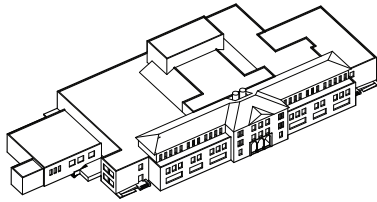
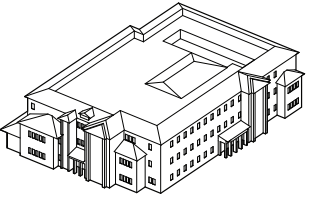
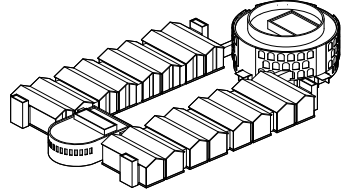
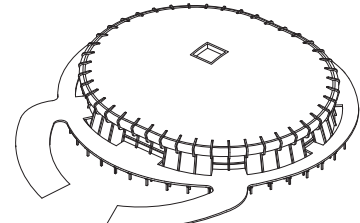
HISTORIC CORE	CONTRIBUTING STRUCTURE	CONTEMPORARY-LITERAL	CONTEMPORARY-INTERPRETIVE	CONTEMPORARY-NON REFERENTIAL	NON CONTRIBUTING
 ATKINSON HALL	 JOHN M. PARKER COLISEUM	 LSU EMERGING TECHNOLOGY CENTER	 STUDENT UNION	 SCHOOL OF VETERINARY MEDICINE	 MIDDLETON LIBRARY
 HILL MEMORIAL LIBRARY	 REILLY THEATER	 LSU DIGITAL MEDIA CENTER	 ART AND DESIGN	 TUREAUD HALL	 LOCKETT HALL
 COATES HALL	 GYM ARMORY / COX ACADEMIC CENTER	 FREY COMPUTING SERVICES CENTER	 LIFE SCIENCES ANNEX	 STUDENT RECREATION COMPLEX	 KIRBY SMITH DORM
 MEMORIAL TOWER	 MUSIC AND DRAMATIC ARTS	 STUDENT BOOKSTORE/GARAGE	 BUSINESS EDUCATION COMPLEX	 PETE MARAVICH ASSEMBLY CENTER	

DESIGN GUIDELINES

HISTORIC CORE

Structures categorized as part of the Historic Core are part of the original Quadrangle and are listed on the National Register for Historic Places. These structures were built between the years 1900 and approximately 1939. Some of these buildings have later additions that are not listed on the National Register for Historic Places.

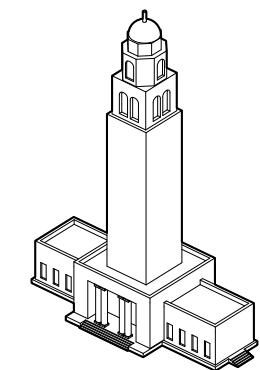
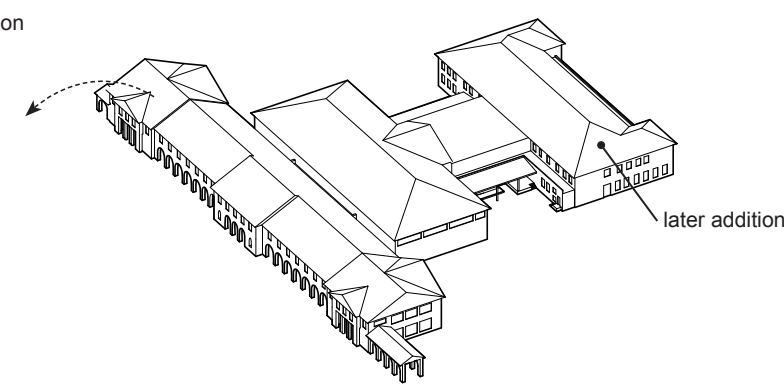
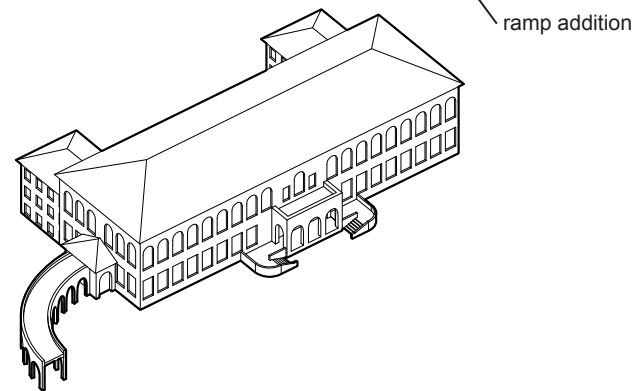
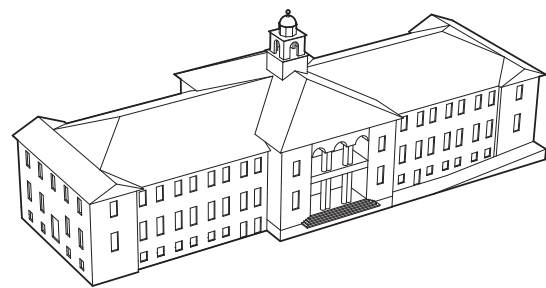

ATKINSON HALL, 1924

- Focal structure anchoring south end of Historic Quad
- Responds to human scale with carefully considered entry sequence
- Long and slender to allow for light penetration and cross ventilation

HILL MEMORIAL LIBRARY, 1924

- Anchors west end of cruciform Historic Quadrangle
- Achieves human scale with entry portico on the east facade
- Covered arcade links directly to Allen Hall

CHARLES E. COATES HALL, 1924

- “Fabric” structure defining the east facade of Historic Quad
- Entire west facade is an arcade linking the Historic Quad along the north-south axis

MEMORIAL TOWER, 1924

- Prominent focal structure, originally conceived as a sally port marking the main entry to campus
- Vertical scale and landmark status makes it a wayfinding tool for campus

DESIGN GUIDELINES

HISTORIC CORE: ATKINSON HALL 1924

Atkinson Hall was built in 1924 and designed by the original architect of the campus, Theodore C. Link. Anchoring the south axis of the main quadrangle, Atkinson Hall is surrounded by trees and a plaza facing main quadrangle to the north, and the College of Art and Design quadrangle to the south. The area is largely pedestrian, though there is a Zone-C reserved parking lot to the east. The building is composed of a central block with two story loggia featuring arches with double columns taking the place of piers, surmounted by a two-stage campanile with domed cupola. The building is made of classic LSU materials: large aggregate stucco, divided lite windows red clay tile roof, and copper cupola.

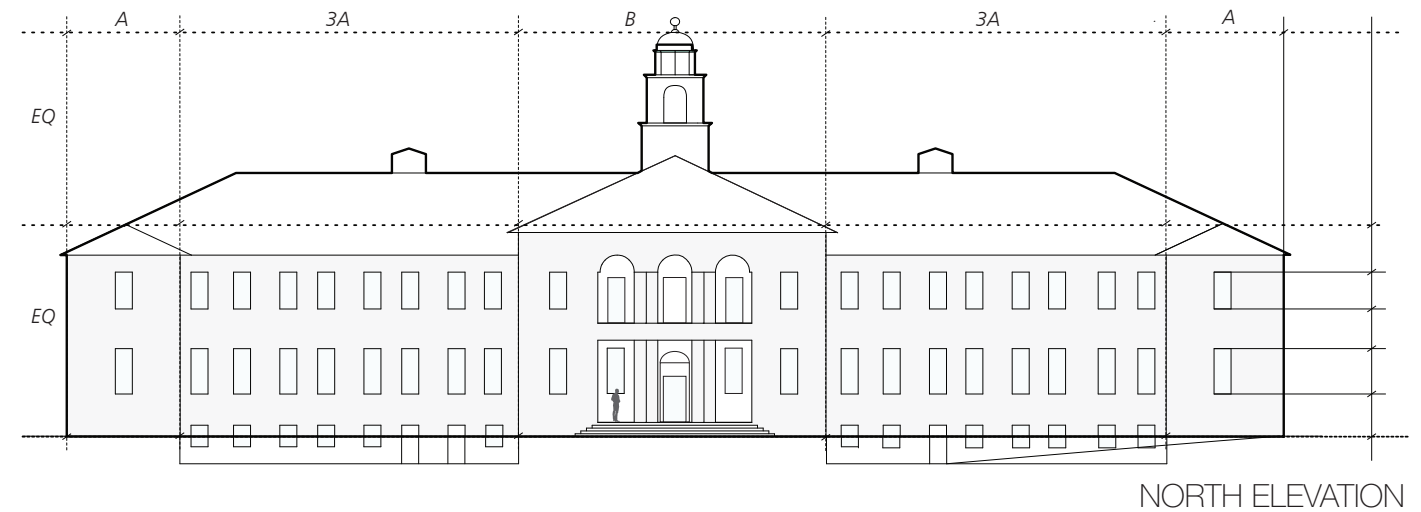
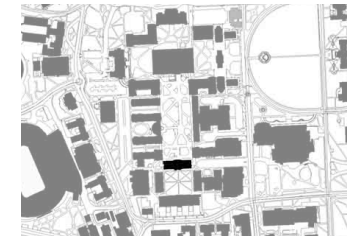

MAIN ENTRY



NORTH ENTRY SECTION

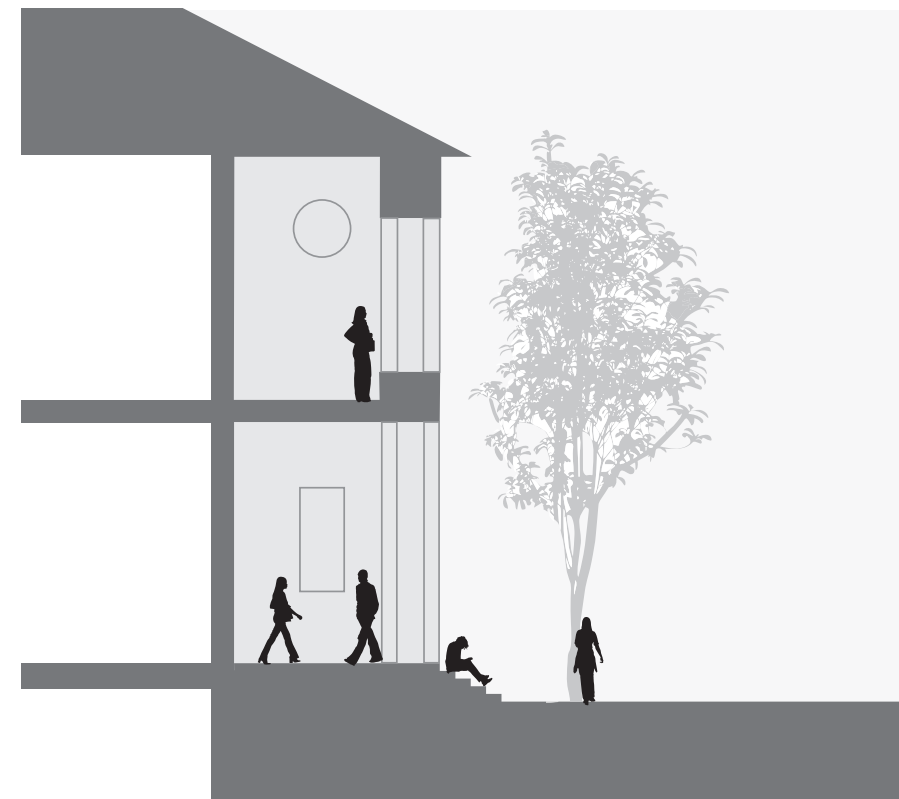

- Layered entry sequence transitions between indoors and outdoors
- Oversized steps allow for comfortable seating
- Second-story balcony offers respite and views of quad

WINDOW TO WALL RATIO OF PROMINENT FACADE

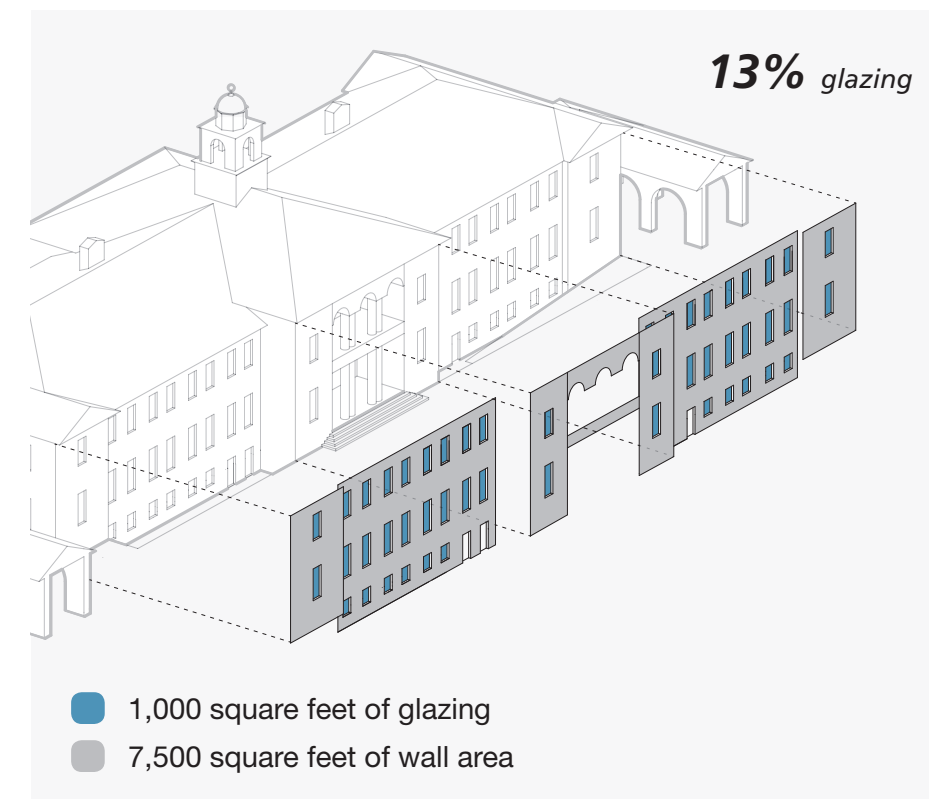

DESIGN GUIDELINES

CONTRIBUTING STRUCTURE

Structures categorized as Contributing Structures include buildings built at approximately the same time as the core or shortly thereafter. These structures are designed to fit within the historic fabric of the core or have unique historical architectural significance on campus.

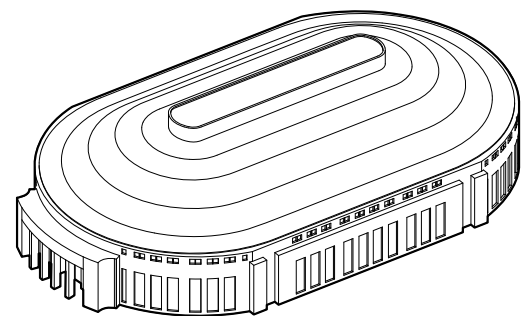

JOHN M. PARKER COLISEUM, 1937

- Located south of Campus Lake and adjacent to large livestock barn
- Clerestory windows and a large light monitor provide significant daylighting and natural ventilation

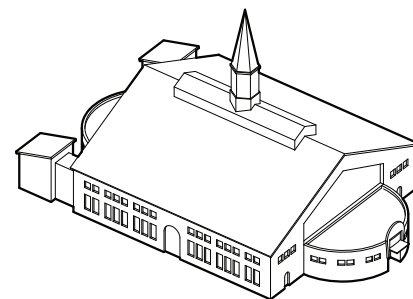

REILLY THEATER, 1923

- Originally the Swine Palace livestock pavilion, Reilly Theater was the first building acquired by LSU
- Underwent major renovation and reopened in 1999
- Home to the Swine Palace professional theater company

FABRIC BUILDING

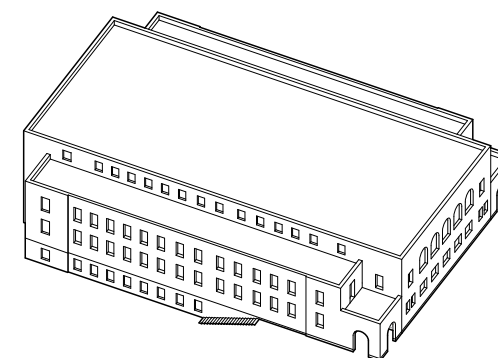

GYM ARMORY / COX ACADEMIC CENTER, 1925

- Built using St. Joe brick unlike the rest of campus at the time which was stucco
- The first large indoor assembly space on campus, the Gym Armory functioned as a space for athletic events, dances, and an auditorium

FABRIC BUILDING

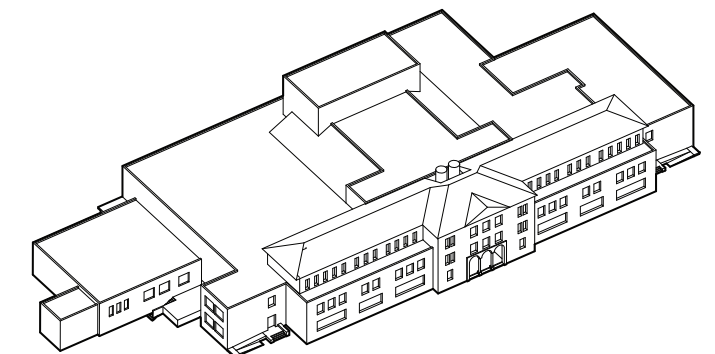

MUSIC AND DRAMATIC ARTS, 1932

- The 101,000 square foot facility underwent a \$22 million renovation in 2009
- Is home to a 424-seat art deco proscenium theater

FABRIC BUILDING

DESIGN GUIDELINES

CONTRIBUTING STRUCTURE: GYM ARMORY 1925

The Gym Armory is located on one of the central spines of campus, Field House Drive, and aligns with the east-west axis of the Historic Core. This building was one of the first built along the existing bluff and closes off the view from main campus to the Mississippi River. The building features a rusticated piano nobile and a second-story with five arched windows separated by pilasters culminating in a full entablature and parapet. Uncharacteristic for buildings on campus at the time, the building has a flat roof and utilizes St. Joe brick for exterior walls instead of the traditional stucco of the Core. Conceived as a freestanding structure, it incorporates covered arcades at each end of the building to denote entrances.

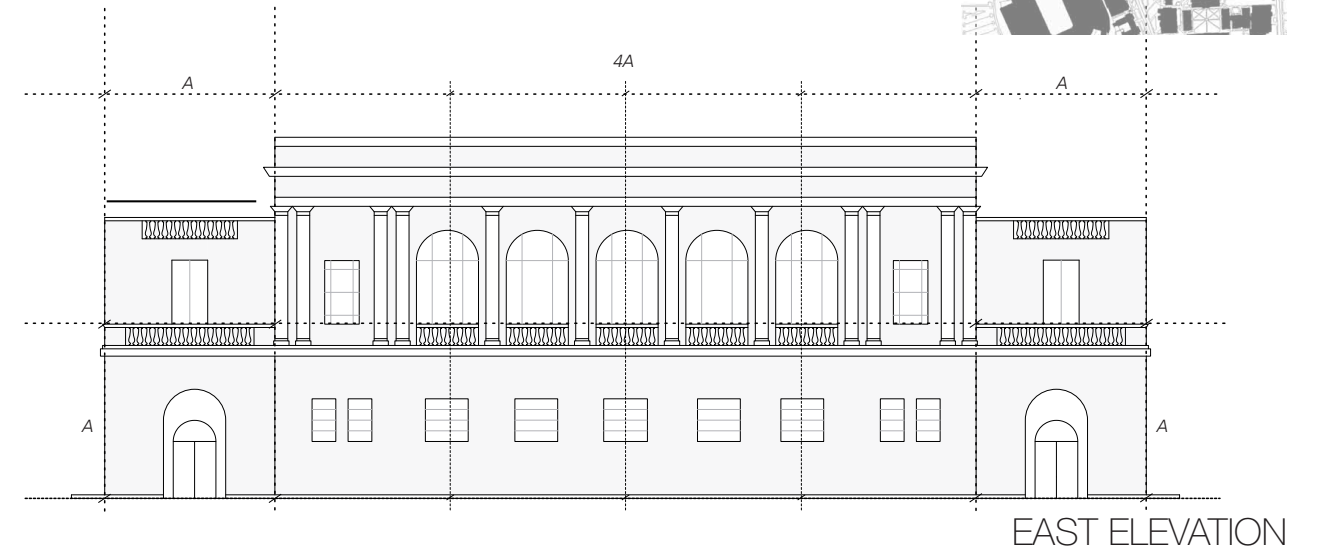
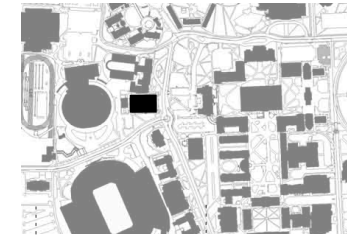

MAIN ENTRY



SOUTH ELEVATION

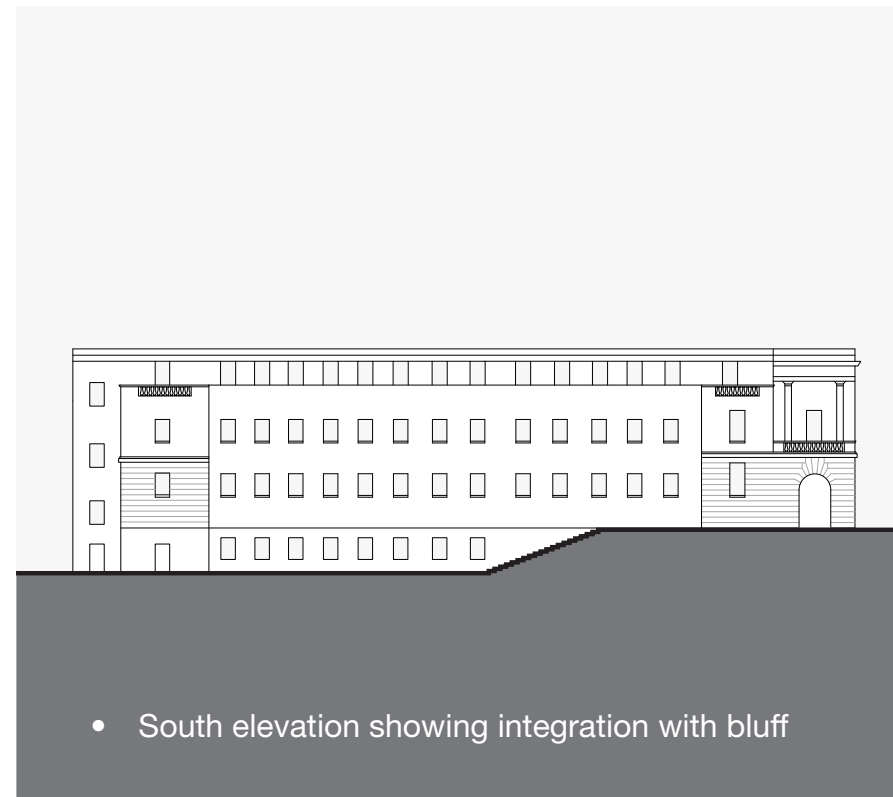

WINDOW TO WALL RATIO OF PROMINENT FACADE

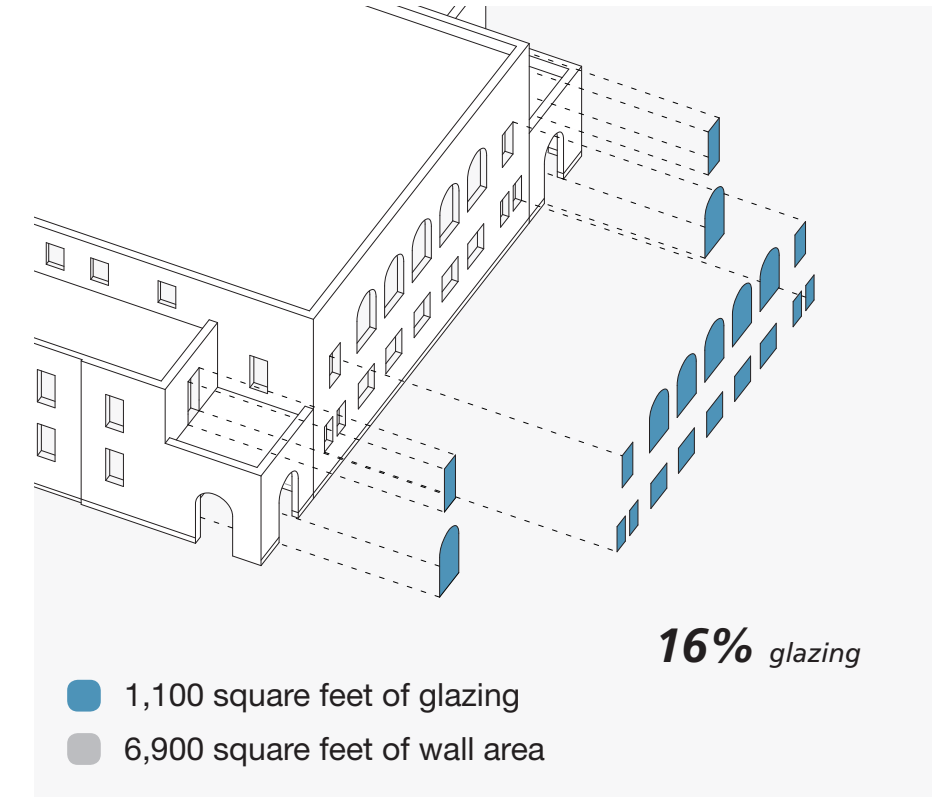

DESIGN GUIDELINES

CONTEMPORARY - LITERAL

Structures categorized as Contemporary-Literal are buildings completed post-1949 and directly reference, or imitate, components of architecture of the historic core.

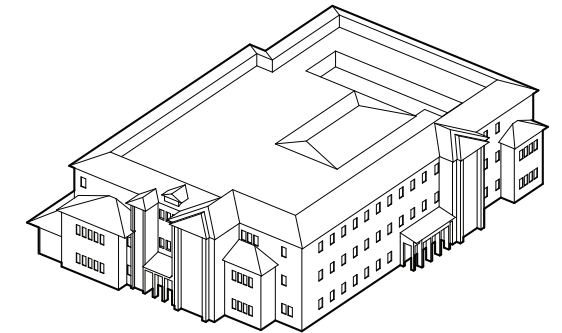
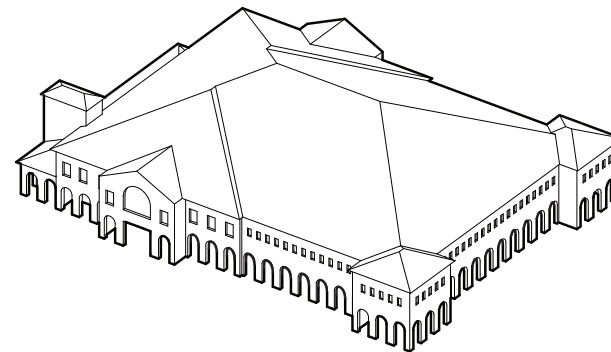
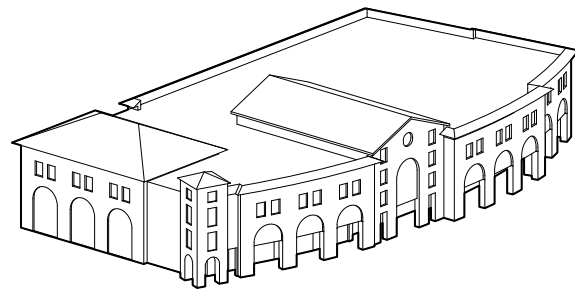
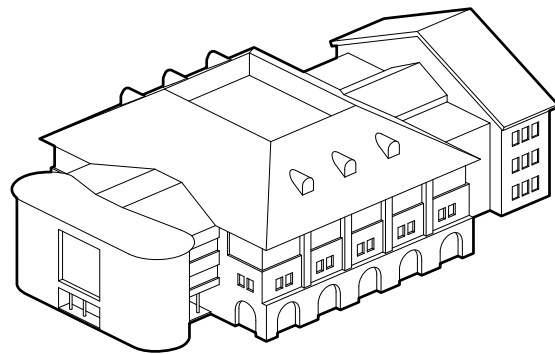

EMERGING TECHNOLOGY CENTER, 2002

- 64,000 square foot facility incubator space for commercializing University technologies
- Includes wet-labs for biotech, agricultural, life sciences, and environmental industries research

DIGITAL MEDIA CENTER, 2014

- 100,000 square foot facility
- Houses the LSU Center for Computations and Technology in 50,000 square feet
- Private-sector tenants occupy 30,000 square feet

FREY COMPUTING SERVICES CENTER, 1996

- Measures 205'x132' and is 56,000 square feet between two floors
- West and south facades are surrounded by arched arcades

STUDENT BOOKSTORE/PARKING GARAGE, 2013

- Building houses Barnes & Noble Bookstore, 750-stall parking garage, Women's Center, and African American Cultural Center
- Features traditional LSU materials: stucco, red clay roof, and brick

DESIGN GUIDELINES

CONTEMPORARY - LITERAL: EMERGING TECHNOLOGY CENTER 2002

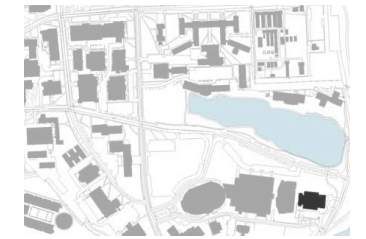

The Louisiana Emerging Technology Center uses many materials and motifs from the original buildings of the Historic Core like pitched red clay tile roofs, St. Joe brick, arcades, and tripartite divisions. The motifs, however, serve a different purpose. Rather than as a covered walkway, the arcade forms are infilled with glazing along the north and south facades. An oversized arch denotes the main entry to the building on the east façade. The LETC also utilizes black mullions on black glazing which gives large expanses of glazing a uniform opaque appearance.

The building is located in a part of campus that currently undergoing growth and change. However, the building currently stands as an island on the site and does not utilize landscape elements to create layering, depth, or shade.

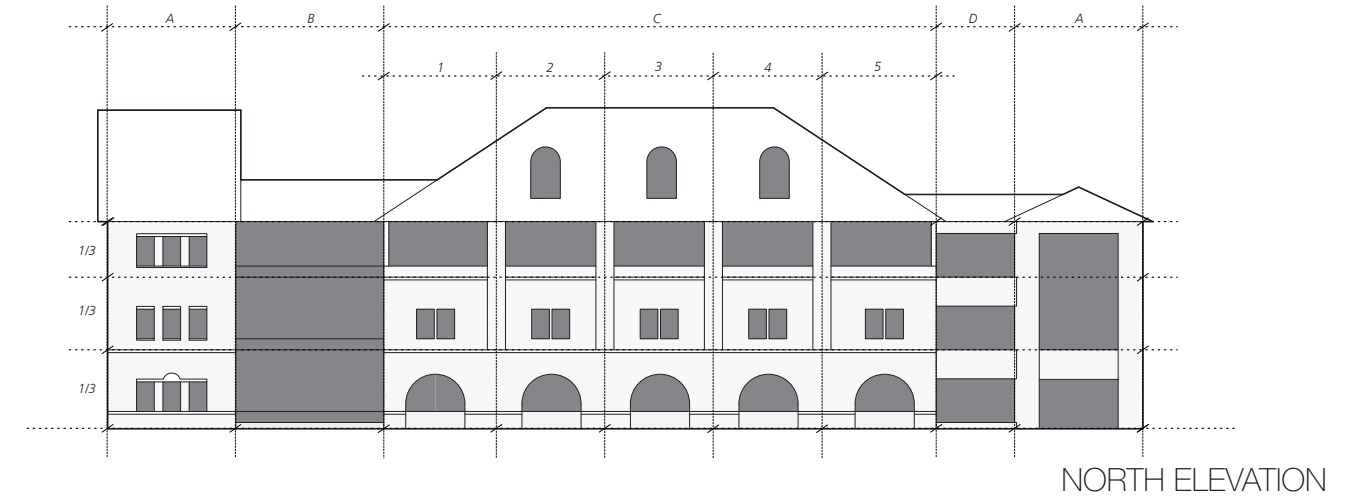

MAIN ENTRY



AREA PLAN

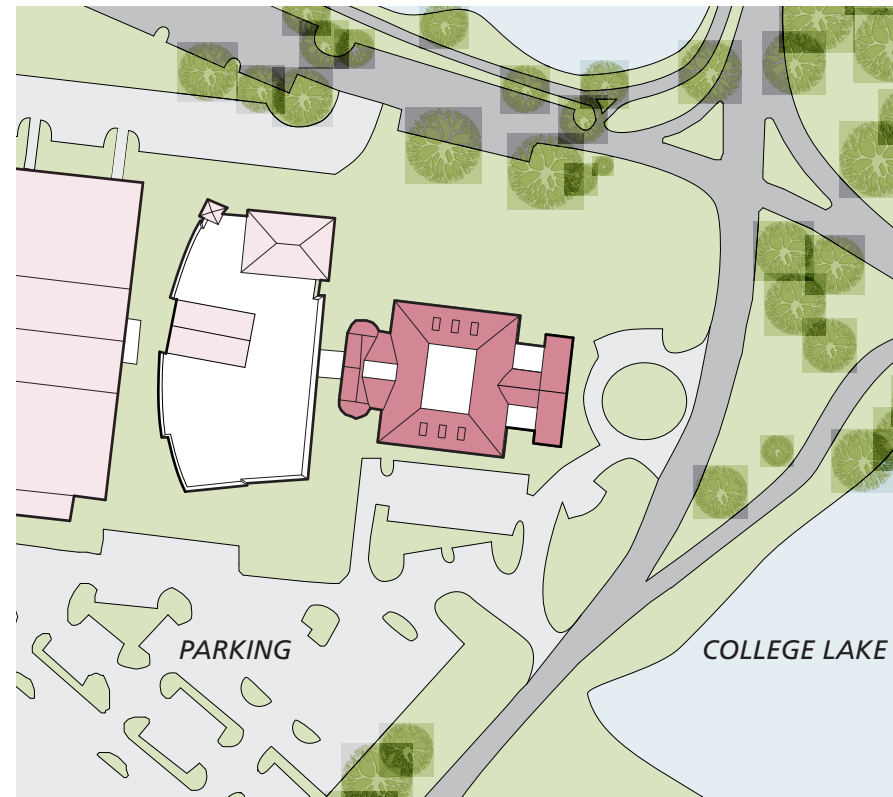

WINDOW TO WALL RATIO OF PROMINENT FACADE

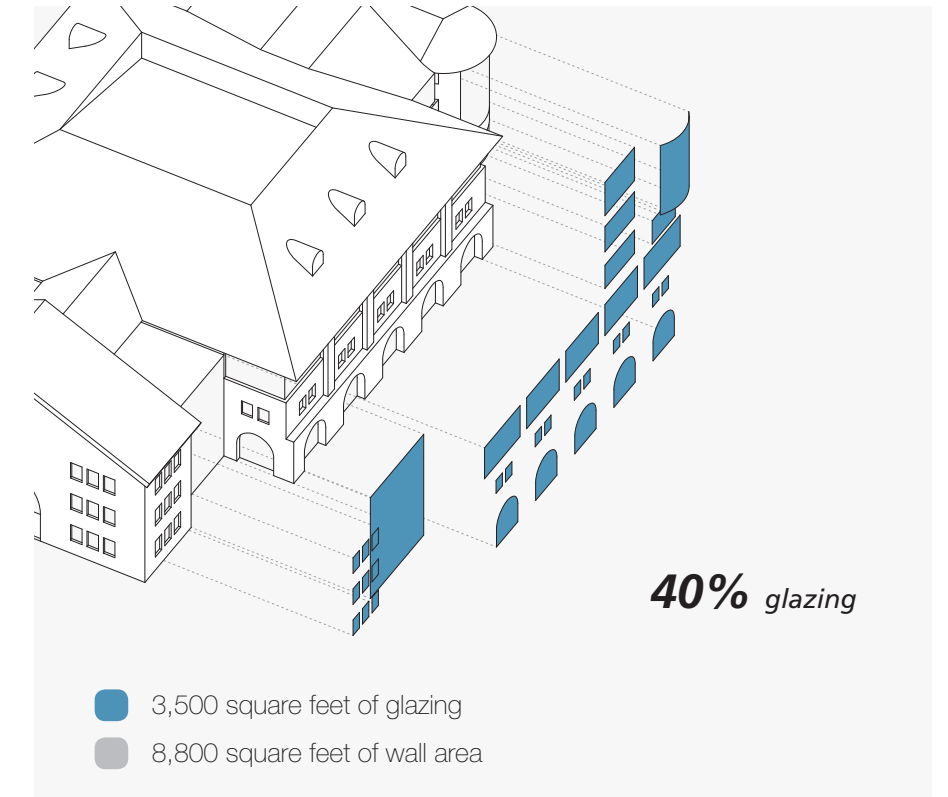

DESIGN GUIDELINES

CONTEMPORARY - INTERPRETIVE

Structures categorized as Contemporary-Interpretive are buildings completed post 1949 that reference particular elements and functions of the historic architectural character and interpret them to adapt to contemporary design and performance goals.

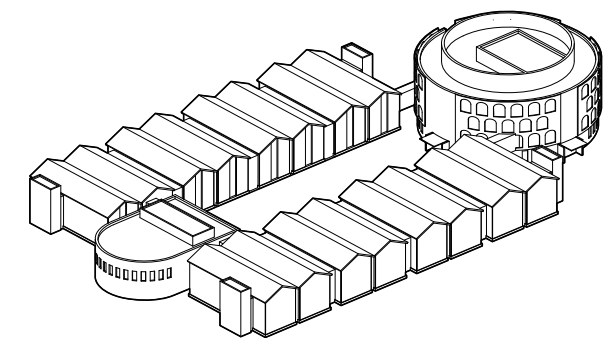
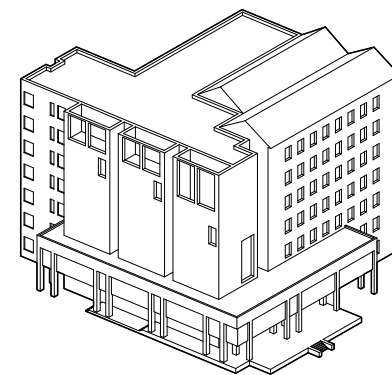
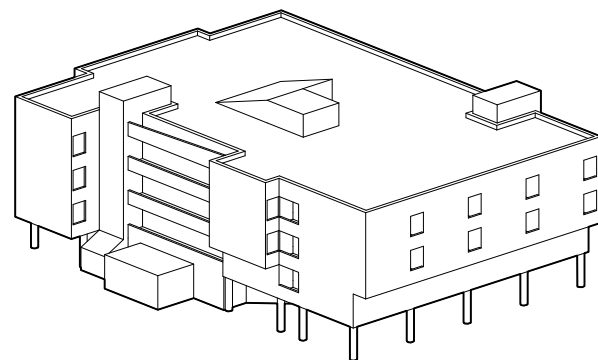
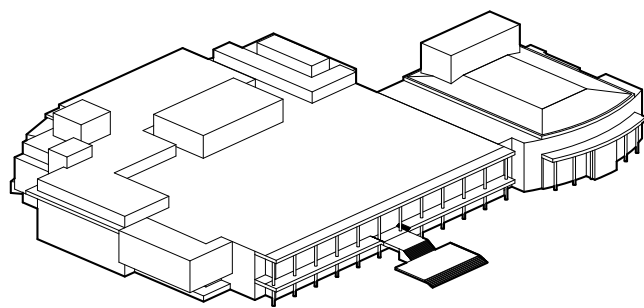

STUDENT UNION, 1964

- Located centrally on campus, the Union provides a transparent and welcoming student hub
- Built in 1964, expanded in 1987, renovated in 1997 and again in 2011
- Reinterprets and advances campus design vocabulary

ART AND DESIGN, 1983

- Located between Tiger Stadium and the sculpture quad
- Utilizes St Joe brick and flat roof profile
- Balconies on each floor increases sense of depth and provide needed articulation

LIFE SCIENCES ANNEX, 2001

- Utilizes arcade as a humanizing element to reduce building scale
- Maintains use of traditional St Joe brick, but in contemporary manner

OURSO BUSINESS SCHOOL, 2012

- Fritted yellow glass and gable roofs mimic the material, color, and massing of historic core
- Very little connection with surrounding context or campus at-large; internally focused building

DESIGN GUIDELINES

CONTEMPORARY-INTERPRETIVE:STUDENT UNION 1964

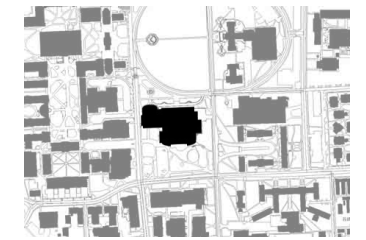

On the LSU campus, the Student Union's entire north facade features storefront glazing which offers expansive views of the adjacent oak trees and parade grounds beyond. The building's structure is not only exposed but celebrated in the double-height main space with branching concrete columns supporting a waffle slab and mimicking the oaks beyond. Both indoors and out the Union's split-level design offers a variety of seating. Outdoor users are protected by a low retaining wall with ample shade from the oaks. Indoors there is ample seating on the very public main floor which is eye level with the oaks. For a greater sense of privacy, the mezzanine level offers seating as well. The changes in light and movement of people in and out of the Union makes for a dynamic north façade. The large oak trees change with the seasons and create dappled shadows.

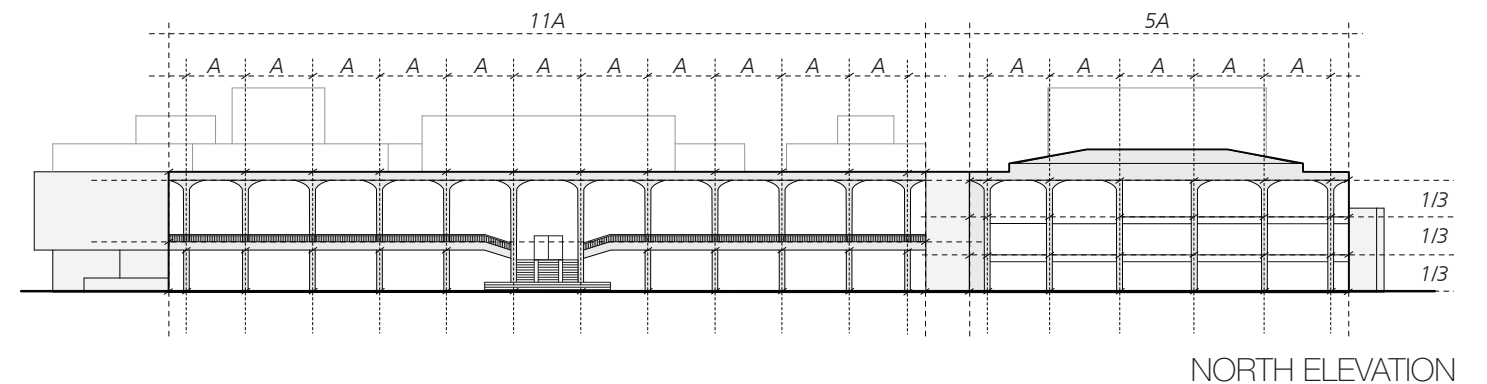

MAIN ENTRY



ENTRY SECTION

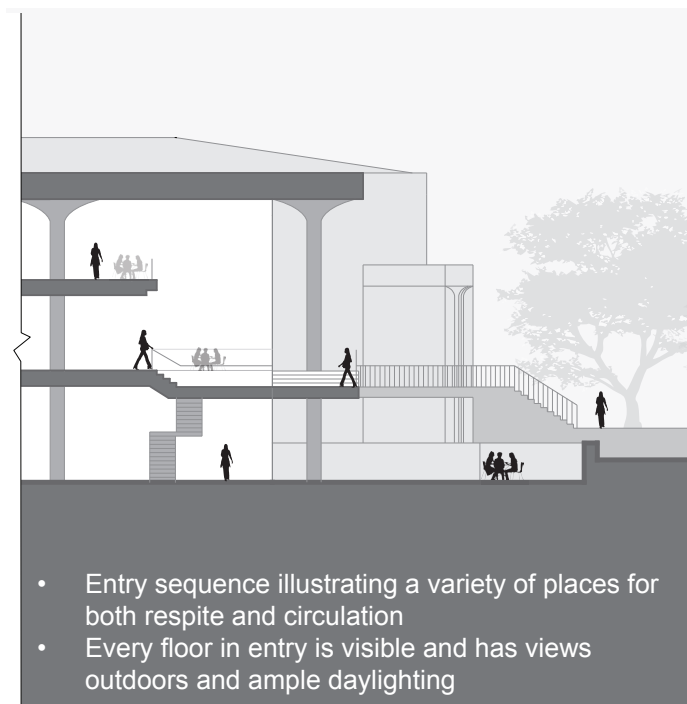

WINDOW TO WALL RATIO OF PROMINENT FACADE

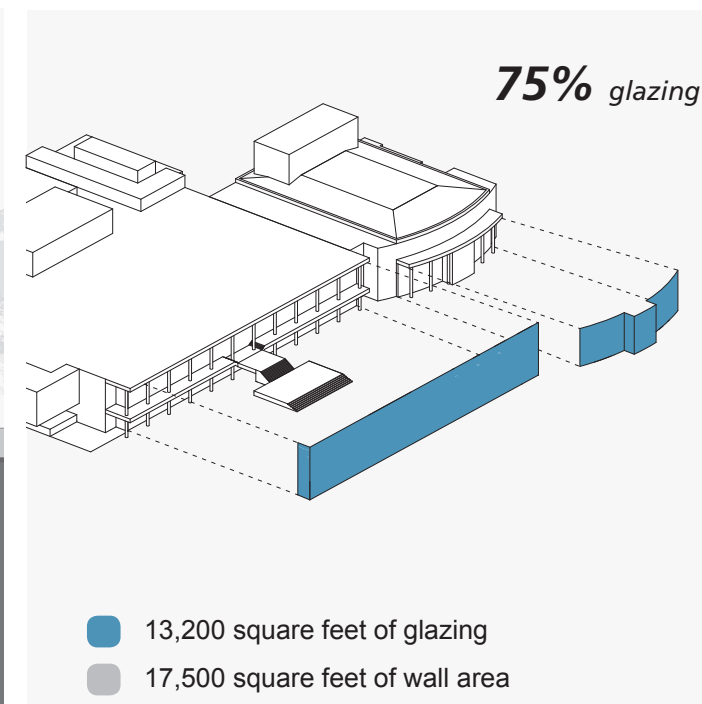

SITE PLAN - TREE DENSITY

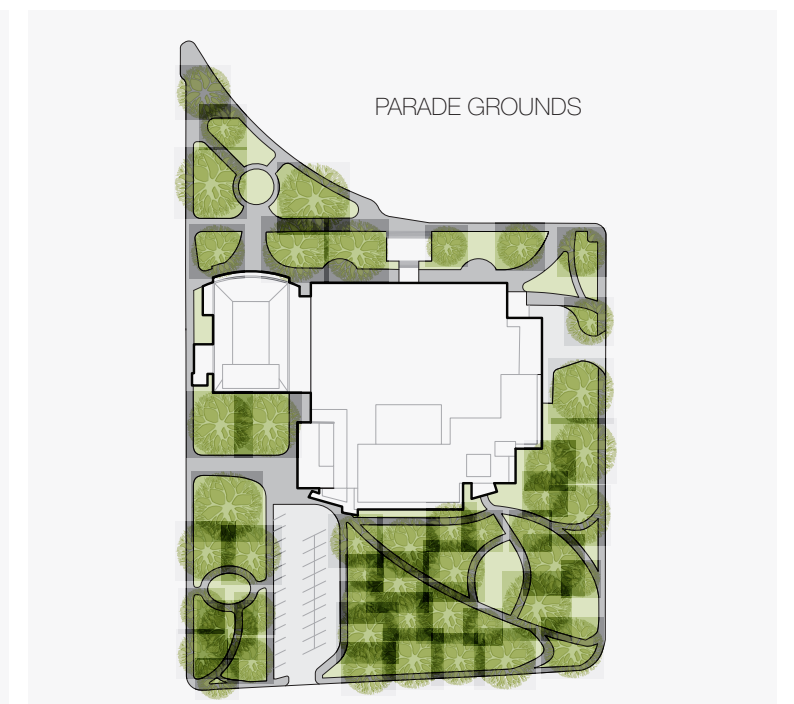

DESIGN GUIDELINES

CONTEMPORARY - NON REFERENTIAL

Structures categorized as Contemporary-Non-Referential are buildings completed post 1949 that are unique in their own architectural character and do not specifically reference the historic core.

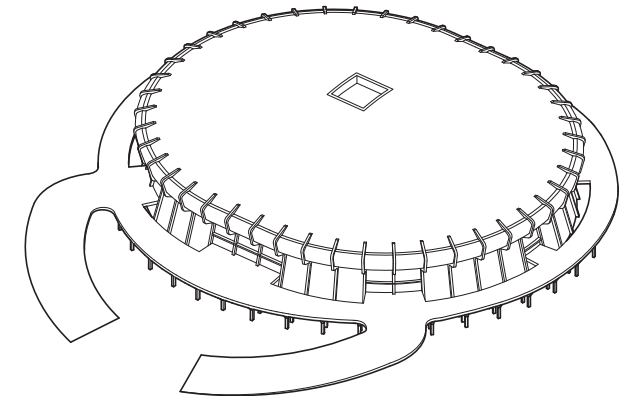
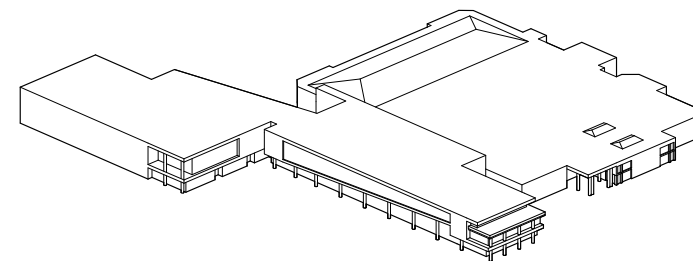
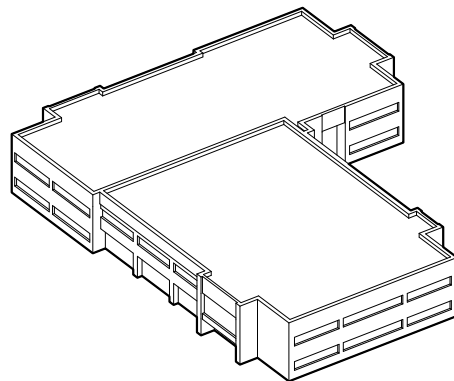
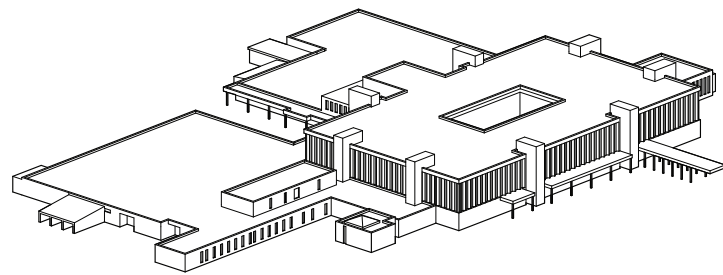

SCHOOL OF VETERINARY MEDICINE, 1978

- Occupies lowland area between Tiger Stadium and Mississippi River
- Original structure is 3-stories and 300,000 square feet
- Large central courtyard brings light to interior of large building mass

TUREAUD HALL

- Predominantly St. Joe brick with reflective opaque windows
- 2-story building in approximately 48,000 square feet

STUDENT RECREATION COMPLEX, 2017

- Significant formal and material departure from architecture of LSU
- 257,000 square feet
- Facility includes lazy river, suspended running track, climbing wall, and high ropes course

PETE MARAVICH ASSEMBLY CENTER, 1971

- 14,104-seat stadium primarily for basketball, gymnastics, and volleyball
- 23,000 square feet arena floor in 211,529 gross square feet

DESIGN GUIDELINES

CONTEMPORARY - NON REFERENTIAL: SCHOOL OF VETERINARY MEDICINE 1978



The School of Veterinary Medicine resides in the lowland between the Mississippi River and Tiger Stadium. The original 3-story, 300,000 square foot facility was built in 1978. The large building footprint is mitigated through the use of a large central courtyard for daylight and wayfinding. While the building is quite modern in comparison with the LSU's Historic Core, it shares many features. It abides by the same symmetry and restraint, and the arrangement of volumes gives a sense of weight and depth. The building also features the same large aggregate stucco as the Core.

Although the building may appear authoritarian in scale and location on the site, it does not lack texture or medium grain detail. The prominent stair towers break each façade into thirds. At a finer grain, those three sections of façade are fluted with recessed windows. Finally, the window's mullions subdivide each linear window.



MAIN ENTRY

NORTH ENTRY SECTION

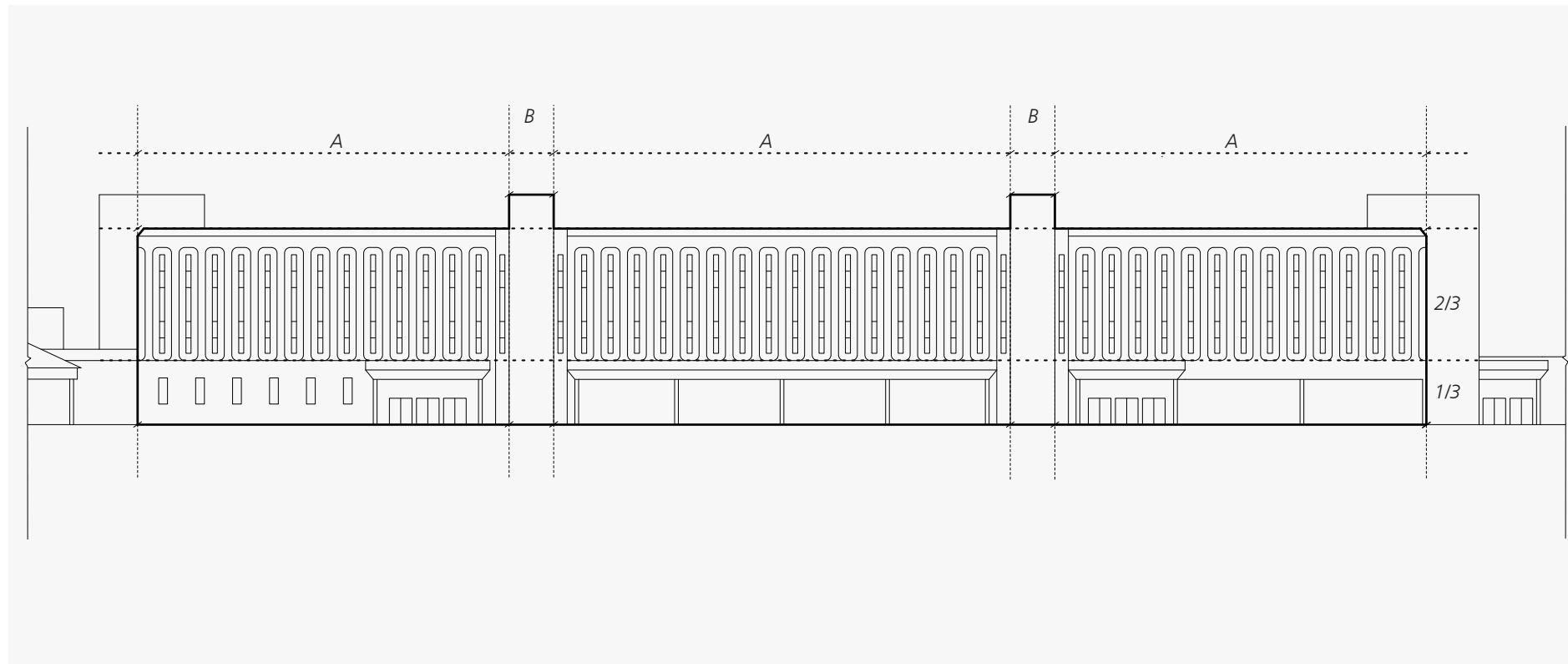

WINDOW TO WALL RATIO OF EAST FACADE

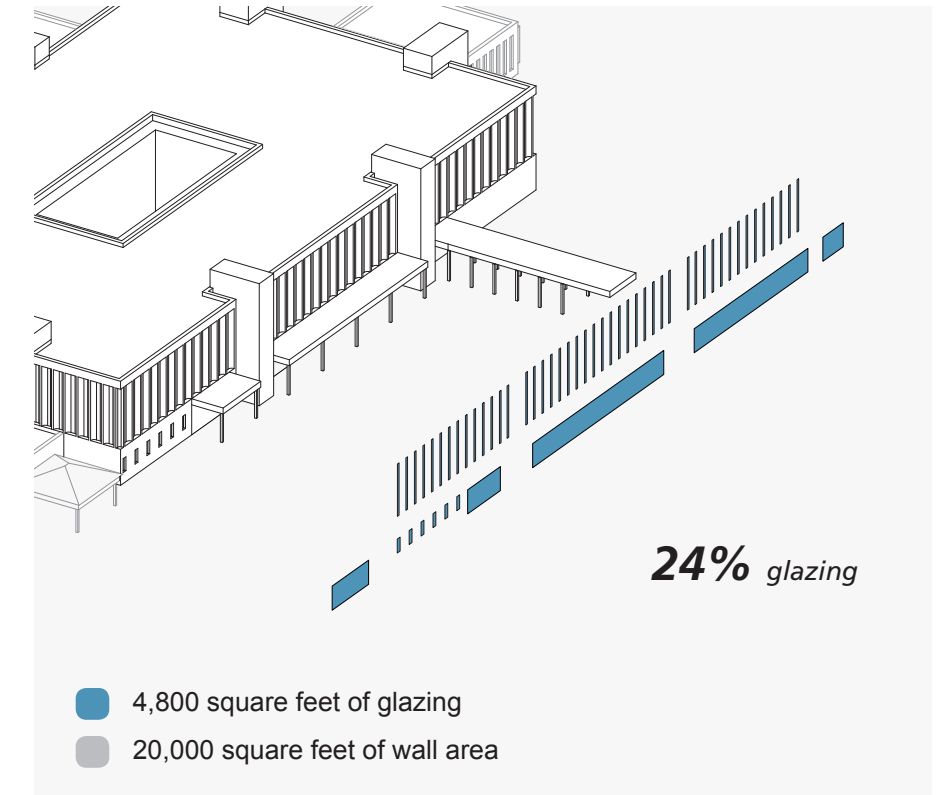

DESIGN GUIDELINES

NON CONTRIBUTING

Structures categorized as Non-Contributing are buildings that express no contributing architectural character to the fabric of the campus, and also one of poor condition with high deferred maintenance needs.

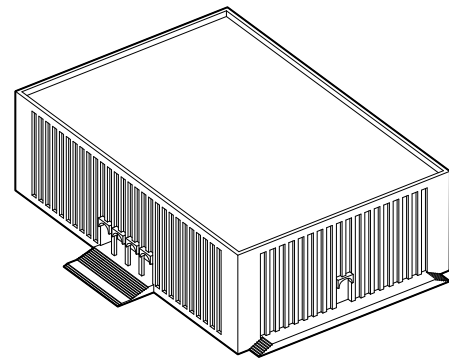

LOCKETT HALL, 1969

- Adjacent to Historic Core on west side
- Unique to buildings of Core in form and scale, but similar in color and entry arches
- Slot windows on all four sides of building provide minimal daylighting of interior

FABRIC BUILDING

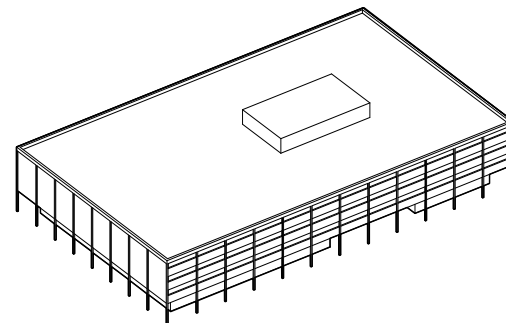
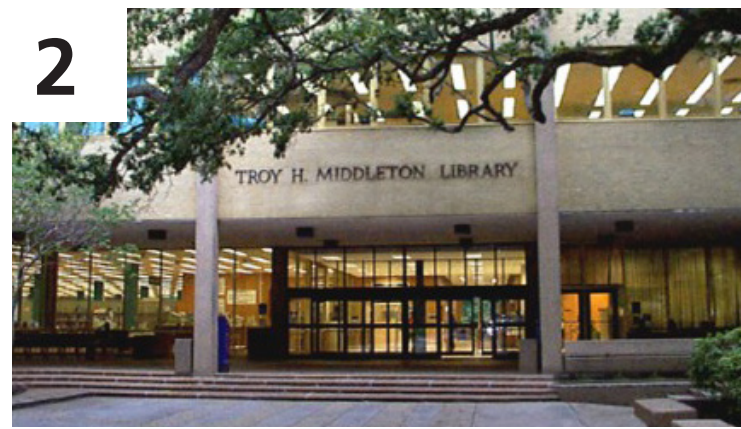

MIDDLETON LIBRARY, 1958

- Located in the center of the Historic Quad but built 40 years later
- Predominantly brick facades with terracotta tile walls
- Minimal access to daylight in interior mass

FABRIC BUILDING

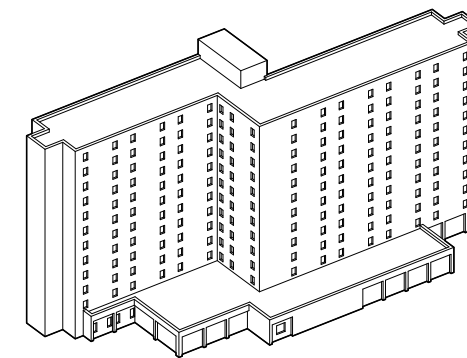

KIRBY SMITH DORMITORY, 1967

- Located on north end of campus adjacent to small residential buildings
- One of the tallest buildings on campus at 154 feet (Memorial Tower is 175 feet tall)
- Completely unrelated to context and scale of campus

FABRIC BUILDING



The best campus experiences at Louisiana State University are those spent **walking through dappled shadows** toward buildings where light and activity shines through **deep, layered facades**. The campus is defined by a building fabric that unfolds as students move through the lawns and live oaks of its unique southern landscape. At their best, its buildings acknowledge the architectural legacy of the early Italian Renaissance quad, while also representing their time, forming a continuous, cohesive timeline. Classes and activities often spill into the outdoors during the mild weather of the academic year, and these outdoor **social spaces shape LSU life**. The following seven principles for design are meant to guide and inspire campus design that reinforces this experience and create a cohesive campus identity that transcends architectural style.

DESIGN GUIDELINES

1.4 DESIGN PRINCIPLES

- TIME AND PLACE Create buildings sensitive to both time and place.
- LINKAGES Extend beyond a building site and work within the full campus framework.
- LAYERING Design landscape and buildings as an integrated spatial environment.
- SOCIAL SPACES Create placemaking opportunities which enrich campus context.
- HUMAN SCALE Respect human scale and integrate with context.
- DESIGN ELEMENTS Utilize materials and elements which reinforce campus identity and character.
- SUSTAINABILITY Campus design should be resilient, effectively utilize resources, and promote health.



DESIGN GUIDELINES

PRINCIPLE 1: TIME AND PLACE

Create buildings **sensitive to both time and place**. Designers should respect the historic context of the campus while also addressing both the challenges and opportunities of contemporary learning environments. New buildings should be neither faux historic replications nor pure expressions of modernity, but **unique contributions to context, knitted together by the timeless Louisiana landscape**.

LSU's architectural identity is expressed by a careful attention to scale, material articulation, form, and organization that transcends a specific era or style. It is an architectural expression which speaks to permanence, visual weight and durability, while also providing a delicate articulation which humanizes the architecture. It is the careful balance of those two forces which allows the architecture to feel simultaneously monumental and delicate. Designers should strive to understand these concepts in order to integrate into the established context of the campus.

The campus landscape should reflect its design heritage as well as the **intrinsic character of the local ecology**, taking into consideration the topography, hydrology, soil, and exposure of each site. Successful campus landscapes rely on components of open lawn, canopy, and paths to establish a walkable, human-scale that knits the campus together.

DISTRICT CONSIDERATIONS

LEARN SOUTH CORE

- Work in the core will include mostly restoration and renovation with very little new construction. New construction in this district should be the most sensitive to the scale, materials, and the Palladian organization of the historic core, while honest in its construction techniques and the era in which it was built.
- This district is the university's primary growth vector and represents it as a 21st century academic institution. Its buildings have the opportunity to employ a contemporary design language.
- Architecture in the South Academic District should develop a consistent design through contemporary building programs, construction, aesthetic ideology, and the principles in this document.
- Integrate with the Academic Core by using similar principles of order.
- Communicate construction techniques, technologies, and program honestly.

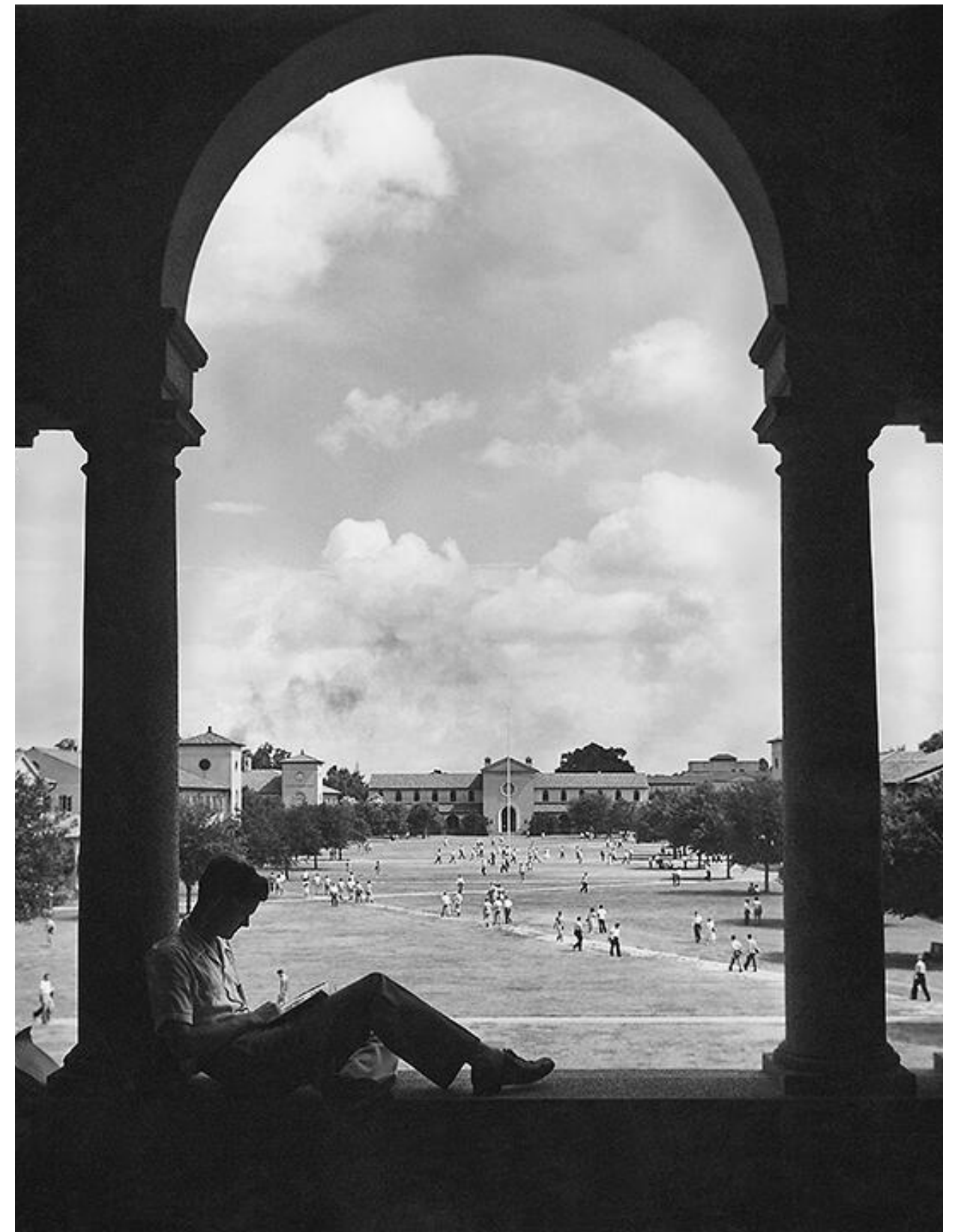

RANGE OF CONTEXTUAL RESPONSE

HISTORIC REPLICATION

CONTEMPORARY REINTERPRETATION



University of Alabama
South Engineering Research Center
2012



Rice University
Duncan+McMurtry Colleges
2009



Louisiana State University
Student Union
1964



Georgia Institute of Technology
Engineered Biosystems Building
2015



MIT
Sloan School of Management
2010



University of Idaho
Albertson Building
2002

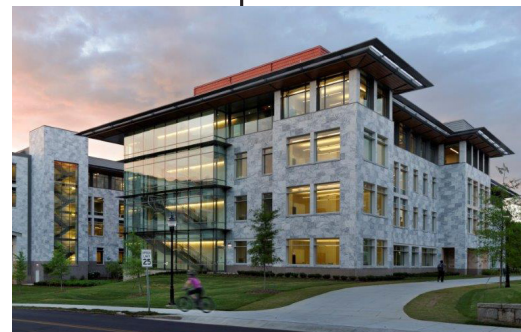

Emory University
Health Sciences Research Building
2013

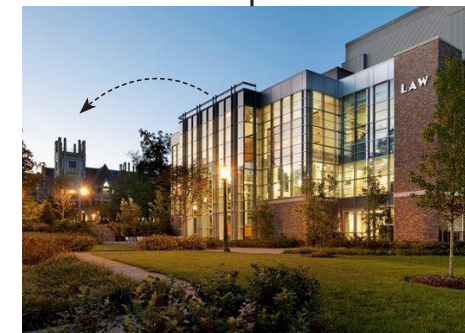

Duke University
Law School Building
2008



University of Arkansas
Steven L. Alexander Design Center
2014

Universities across the country respond to their historic legacy in a wide spectrum of contextual responses. While some institutions insist on blind replication of their historic character regardless of program or scale, others argue that literal imitation **trivializes the historic architecture rather than honoring it**. Many institutions strive for a balanced approach, one which is sensitive to the historic fabric of the campus, while simultaneously reflecting a future-forward, 21st century vision of academic experience.

LSU advocates a balanced contextual approach, weighted toward the contemporary. It's goal is the creation of architecture which is sensitive to historic context, yet "of its time" in reflecting contemporary program, technology, and pedagogy.

This approach manifests itself in the 1964 Student Union Building, a beautifully contextual design which eschews the replication of historic elements of the original campus. It is important to note that this timeless architectural design would not have been possible, had there been prescriptive design standards dictating historic replication.

DESIGN GUIDELINES

PRINCIPLE 1: TIME AND PLACE

LSU buildings over the last two decades reflect a wide spectrum of allegiance to the historic core. Each of these buildings communicates a distinct response to historic context, based on its location, program requirements, distance from the core, and the ideology of its time.

HISTORIC REPLICATION**CONTEMPORARY REINTERPRETATION**

The building design of the Frey Computing Services Center, 1996, shows strict allegiance to the campus historic character, more so than to the time in which it was built. Utilizing many of the hierarchical elements found in the historic campus, the building feels “familiar” in character for that reason. The arcade was utilized primarily to soften the building perimeter, rather than as a connecting element to other buildings nearby.



The Tiger Band Hall, 2012, uses materials and building elements that match the historic core, such as aggregate stucco and arcades, but integrates contemporary construction techniques and elements as well. The building design is honest about its materials and construction, with the notable exception of the “false roof” of red clay tile which conceals a flat roof beyond.



Business Education Complex (BEC), 2012, reinterprets the form and scale of the gable-roofed sheds of the historic campus in a clearly contemporary manner, using modern materials in traditional forms. The design utilizes an inner courtyard as an organizing element, which unifies the design internally, but ignores external linkages to adjacent structures. Utilization of landscaping to establish context is nonexistent.



The Student Recreation Center, 2017, departs from allegiance to the architectural character of the campus in materiality, massing, and form. While an honest expression of program through its transparent facade, it eschews any direct or indirect reference to the architecture of the existing campus. While the building envelope exhibits significant articulation and landscaping, the integration of landscape to soften the building is minimal.

DESIGN GUIDELINES

PRINCIPLE 1: TIME AND PLACE

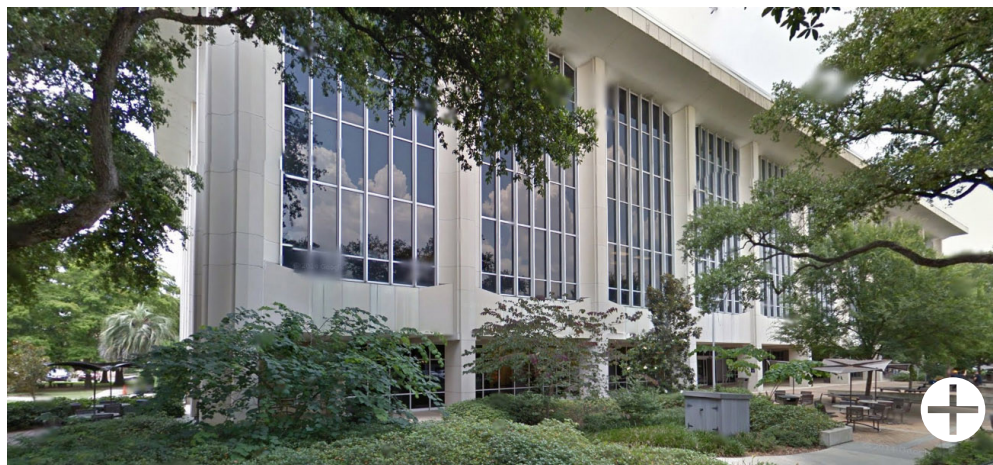

The 60s-ERA Law Center addition speaks through material character, rhythm, monumentality and articulation to its historic counterpart, while representing the construction technology and ideology of its time.



The Louisiana Emerging Technology Center replicates the arched form of the historic core's arcades, but blocks them in, removing their functionality as an inhabitable, connective space. The absence of landscaping and tree canopies creates a harsh pedestrian environment, as compared with the more human-scaled and layered building edges of the central core.

DESIGN GUIDELINES

PRINCIPLE 2: LINKAGES

Thoughtfully considered, human-scale connections that respond to the heavy rainfall and intense sun of the deep South are **fundamental to LSU’s success as a walking campus**. A new construction project can employ many types of linkages to integrate into the campus context, such as arcades, landscapes, and interior building thoroughfares. Linkages that are most effective provide clear wayfinding and direction to campus destinations, mediate architectural changes between buildings, protect openings and entrances, and create engaging experiences. Linkages must allow people of **all physical abilities** and familiarities with the campus to move comfortably and safely; providing seating, lighting, and universal accessibility. Arcades have historically provided linkages between buildings at LSU and, when used in new projects, their design should adapt to contemporary design goals and programmatic challenges while maintaining their historic function. Landscape is an integral part of a linkage, both historic and new, with the benefit of expanding past a project boundary to knit together the campus environment.

The nature of linkages is that they are most functional when they **work within the full campus framework**. Linkages should integrate into the campus circulation network and designers should consider not only the accessibility, safety, and comfort of the linkages within their project, but how they connect with areas around them.



Successful linkages provide safe, comfortable, human-scale pathways connected to the landscape and campus circulation network.

<p>DISTRICT CONSIDERATIONS</p>	<p>LEARN</p>	<p>SOUTH CORE</p>	<ul style="list-style-type: none"> • The Academic Core provides a beautiful case study of a range of successful linkages. • Emphasize North - South linkages as the South Academic District is a major connector of southern parking lots to rest of campus, lowland to highland, and new quad to old quad. • Linkages along the new quad should create boundaries and thresholds where there are no buildings to define this quad along every edge. • Design covered circulation along building facades that border the new quad so that, as the quad develops, people can walk all the way around under covered space like in the Historic Quad. • Orient building entrances along the new quad to connect axially across the quad with other buildings • Use linkages, especially arcades, to repair the fragmented existing development and connect buildings with their context. 	<p>PLAY LIVE</p>	<ul style="list-style-type: none"> • Incorporate stormwater infrastructure in linkages, especially those bordering the Student Spine. • Celebrate Corporation Canal in linkages that bridge it between rec center and residences. • Provide safe, attractive pedestrian routes between off-site parking and residence halls. • Prioritize seating to serve those using multi-modal transit along the Nicholson Spine. • Provide bike infrastructure along the West Community Spine cycle route. • Create pedestrian connections between parking, tailgating areas, and the rest of campus. • Prioritize bicycle safety over traffic efficiency and separate bike lanes from traffic with landscape, grade change, and/or parking lanes when possible.
------------------------------------	--------------	-----------------------	---	----------------------	--

DESIGN GUIDELINES

PRINCIPLE 2: LINKAGES



“CONNECTIVE TISSUE”

The design of the Historic Quadrangle reflected a sensitive understanding that the linkages between and among the buildings was as critical as the buildings themselves.

Originally conceived as a series of formal pedestrian walks between buildings, the central quad gradually evolved in a more informal, organic manner responding to evolving curriculum patterns, maturation of the landscape and evolving social and cultural values.

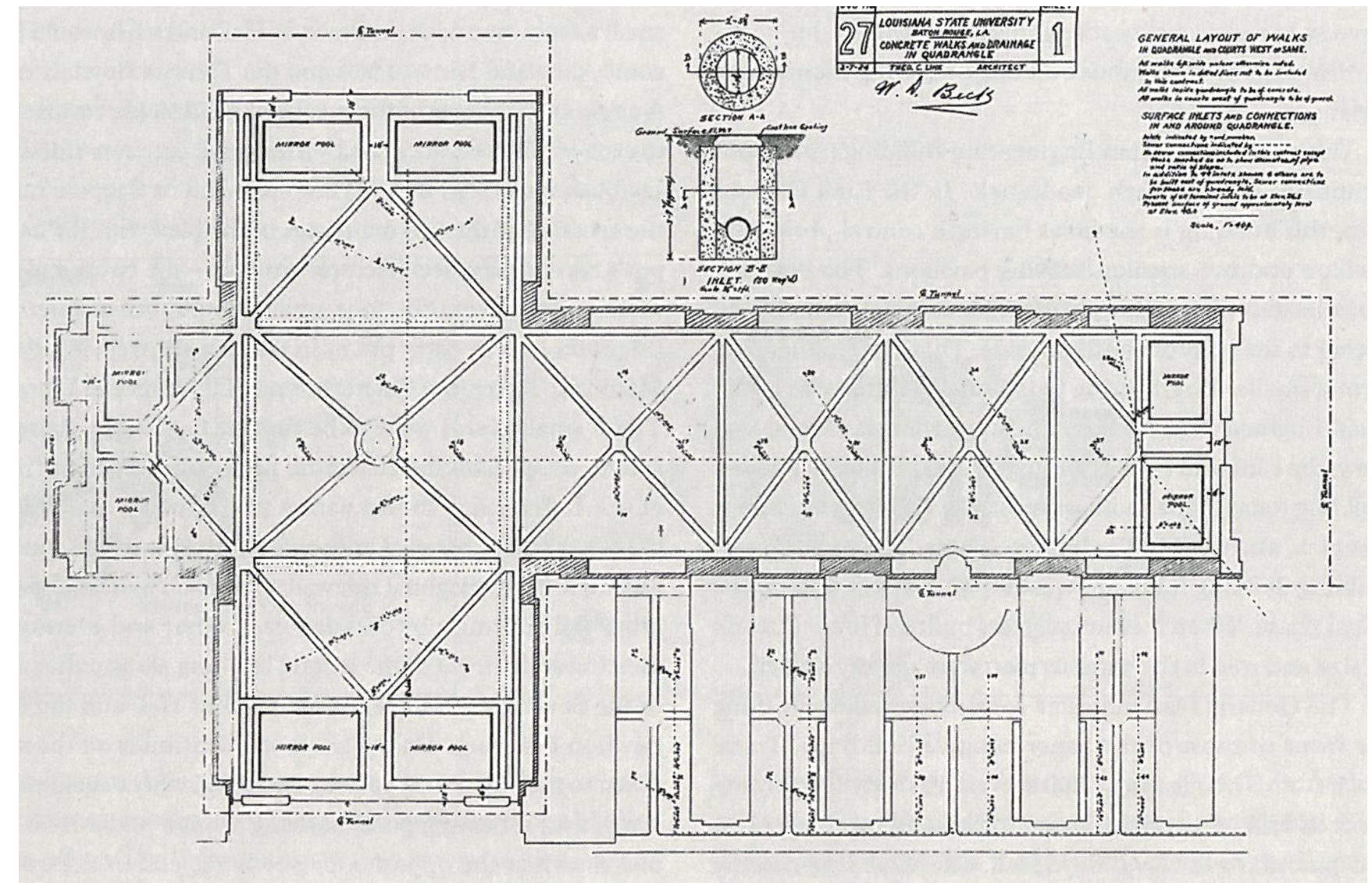

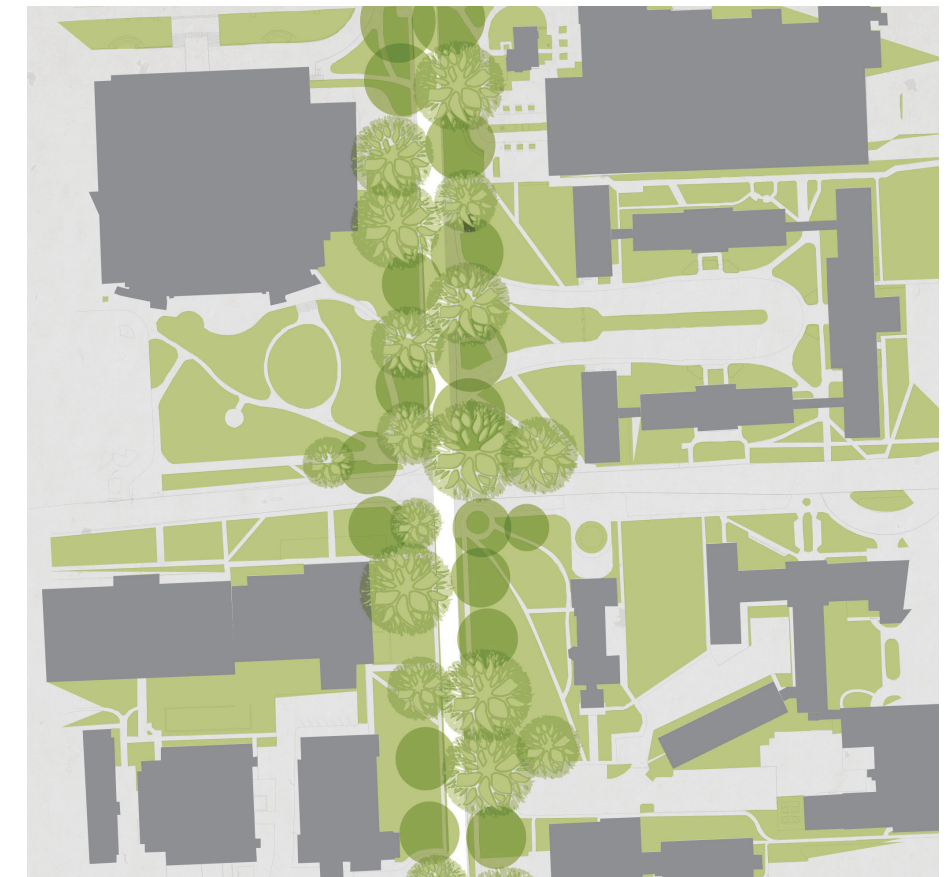
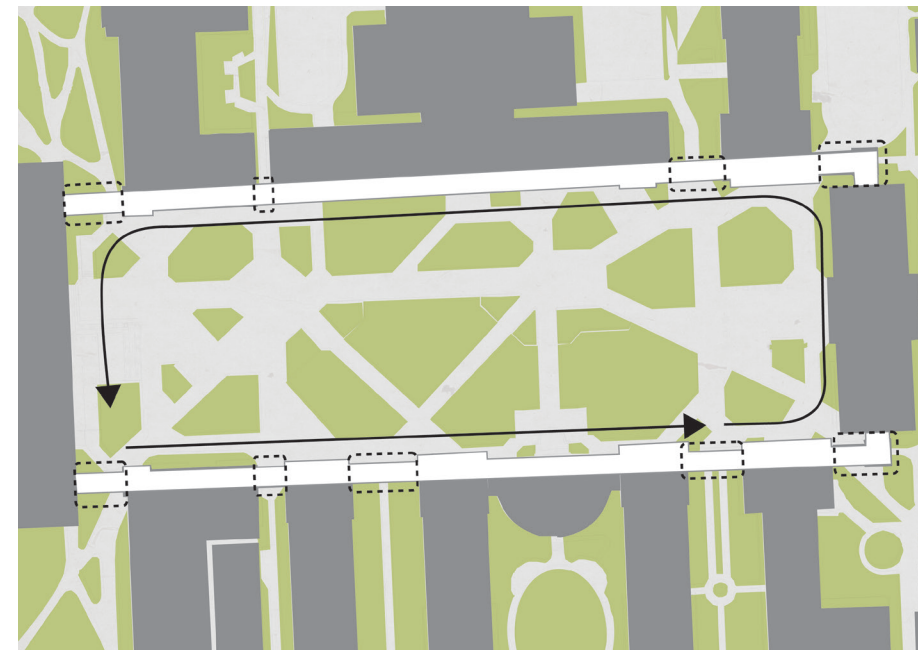
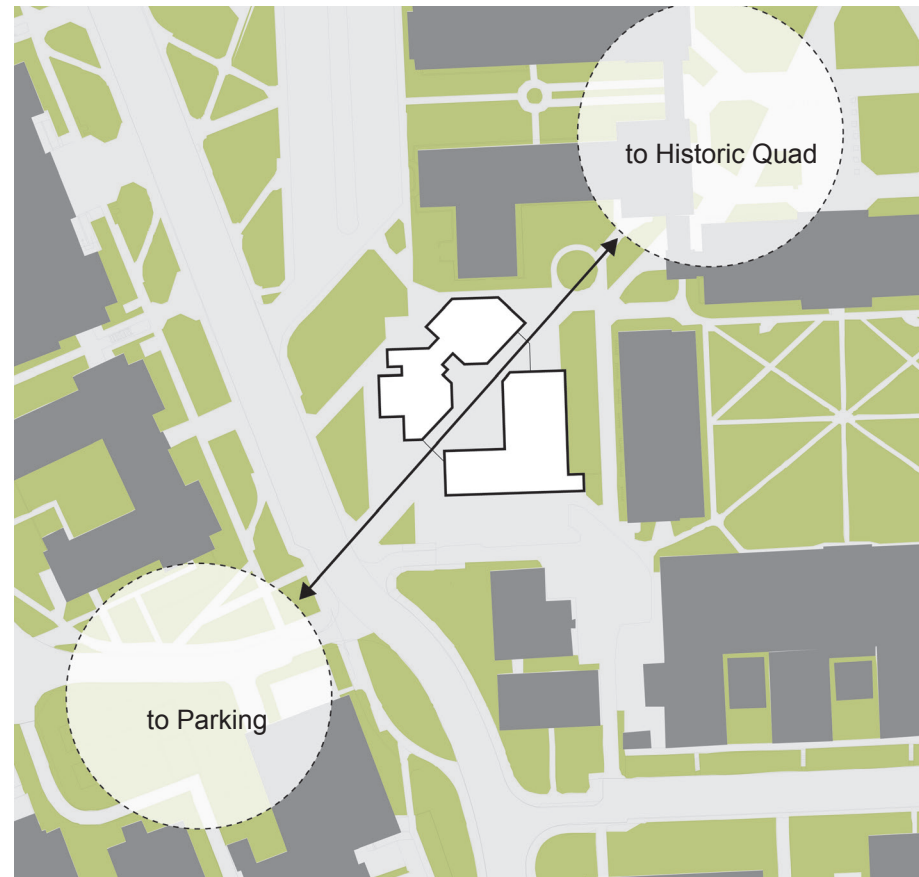

The diagonal linkage within the art and design building connects between major destinations, offers protection from the weather, brings activity to the building interior, and increases interaction between students of different disciplines.



The arched Arcades around the Historic Quad allow pedestrians to walk from one end of the quad to the other in protected, human scale, outdoor space.



Tree-lined Highland road provides several blocks of sidewalk that are protected from the sun, provides human scale, and softens the noise of the busy street.



An insensitive linkage dominated by unarticulated concrete hardscape and lacking any landscape elements



A pedestrian linkage with a complete absence of articulation, layering, human scale or social spaces.



A pedestrian linkage dominated by vehicular and service use



Even modestly scaled linkages can be significantly enhanced by the sensitive use of paving materials, medium-scaled landscaping and site amenities. Well-defined pedestrian paths and grade changes can also enhance the human scale of the design

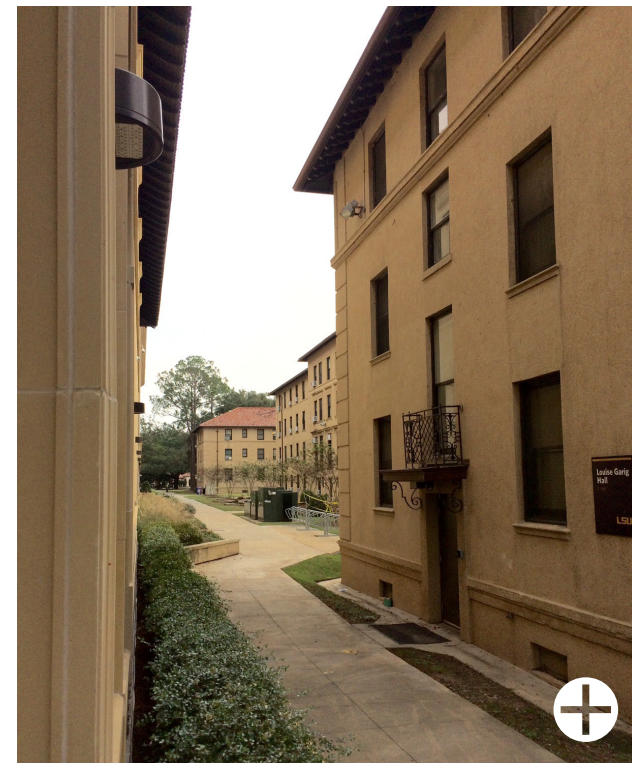

Monumentally scaled architectural conditions are often enhanced by approximately scaled landscape and hardscape elements.

DESIGN GUIDELINES

PRINCIPLE 3: LAYERING

“Where stately oaks and broad magnolias shade inspiring halls...” Herein lies the essence of layering at the campus scale. The signature experience of walking through LSU is one of traveling through layers of shaded, interstitial space where **buildings integrate into the landscape** and unfold on approach. Reinforce this experiential quality with deeply layered facades, filtering landscapes, and pathways designed to direct views, especially around entry sequences. Layering can be **a part of the building architecture, site design, or landscape** and should mediate between indoor and outdoor, control sun exposure, and establish human scale. Use layering to provide an incremental transition between buildings and landscape. Buildings that are perceived as single objects in an open field are not consistent with the character of LSU.

Layering should be a design consideration around buildings as well as between them. Program pathways with a **succession of spatial scales**, such as smaller courtyards and corridors that open into larger areas, to create a campus environment that rewards walking. Use layering to **reduce the mass of large buildings**, establish human scale at the ground level, and provide prospect and engaging views at upper levels. Design layers in such a way that pedestrians perceive landscape and building as an integrated spatial environment - one that is inviting, lively, and connected.



Use layering to provide an incremental transition between building and landscape, establish human scale, and create an environment that rewards time spent outdoors.

<p>DISTRICT CONSIDERATIONS</p>	<p>LEARN</p>	<ul style="list-style-type: none"> • The Academic Core provides a beautiful case study of a range of successful layering strategies. • Renovations and new construction should maintain and augment these layering strategies to preserve the architectural character of the historic core. 	<p>LIVE</p>	<ul style="list-style-type: none"> • Prioritize prospect and refuge to provide a sense of security, territory, and home.
<p>SOUTH</p>	<p>CORE</p>	<ul style="list-style-type: none"> • Use layering to reduce the mass of large buildings and establish human scale at ground level. • Focus layering on pedestrian corridors and social spaces, especially around the edges of the new quad. • Layer the landscape with a succession of spatial scales to repair the disconnected nature of this district. 	<p>PLAY</p>	<ul style="list-style-type: none"> • Use layering to reduce the mass of large buildings and establish human scale at ground level. • Because of the unique program and size of buildings in this district, layering can be at a larger scale and less fine-grained than in academic or residential areas.

DESIGN GUIDELINES

PRINCIPLE 3: LAYERING

The Student Union Building unfolds on approach. There is not one view of the building, but many, as it emerges through layers of landscape and building elements. The architectural depth of this experience, the protection from weather, and the way it breaks the large building into human scale is fundamental to the architectural character of LSU.

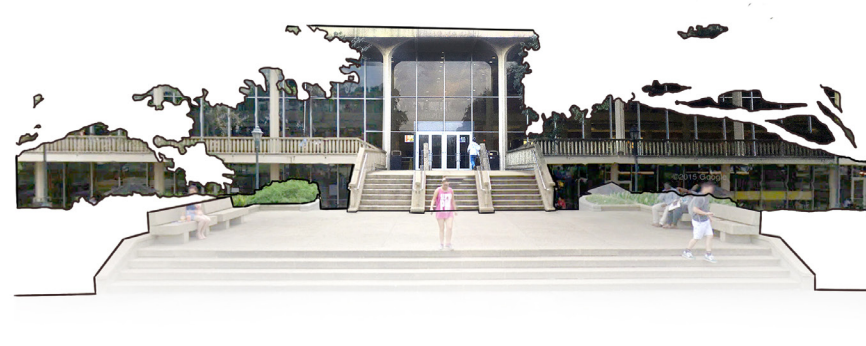
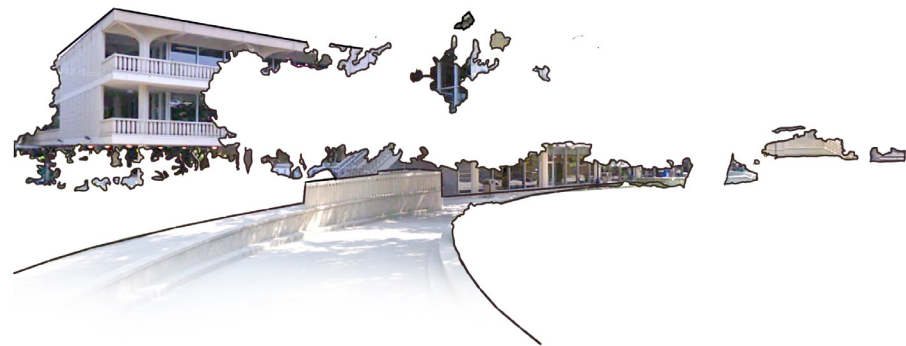

DESIGN GUIDELINES

PRINCIPLE 3: LAYERING

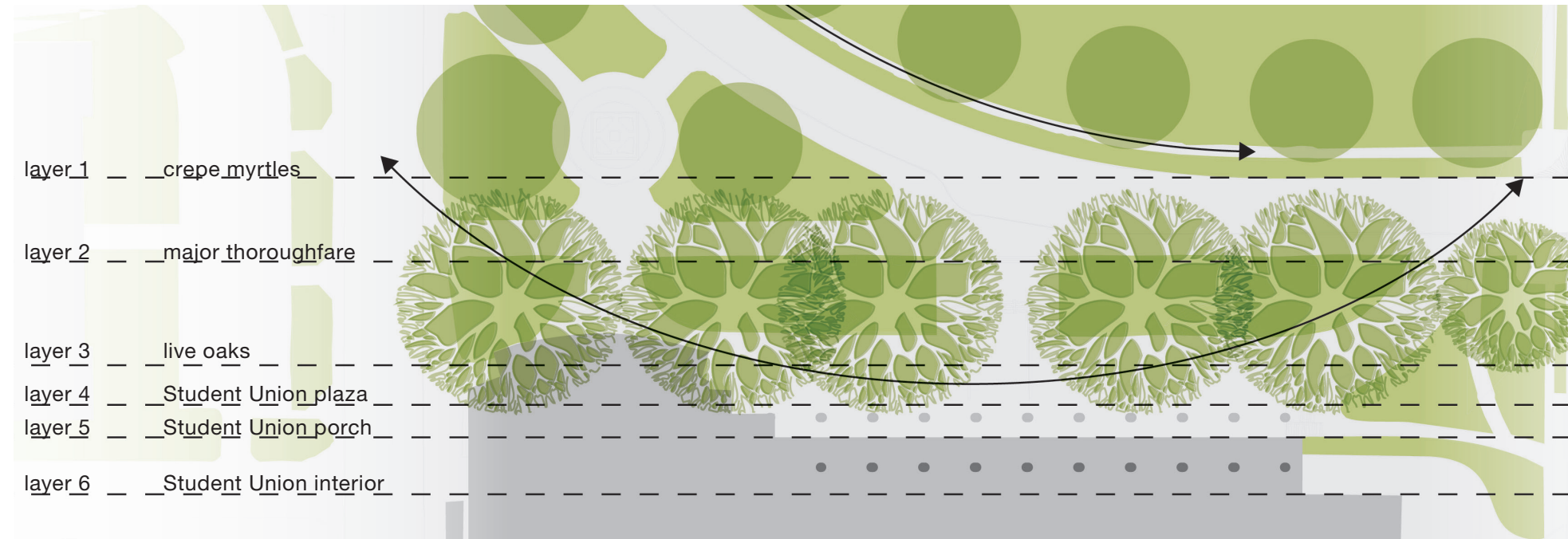

Pedestrians encounter the north side of the student union through several layers of landscape and building elements

The south stair reaches into the landscape



Live oak canopy bridges landscape and building on the north side

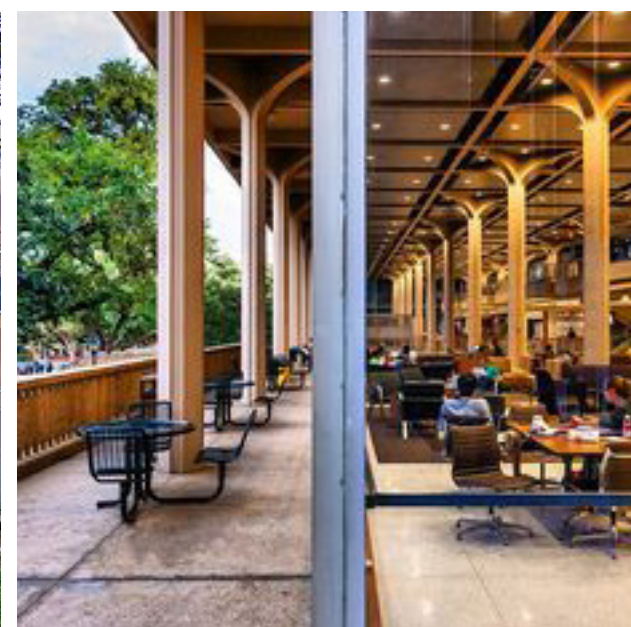

Clear glass unobtrusively separates interior from exterior



Interior architecture and sectional relationships echo the exterior in a united experience

DESIGN GUIDELINES

PRINCIPLE 3: LAYERING

The buildings at right benefit from a change in grade to integrate with their landscape, while the building above is isolated on a flat, open site. Each example employs a colonnade to mediate the change between interior and exterior, however, the Life Sciences Annex colonnade articulates the entrance to the building, whereas the LTRC Training and Education Facility colonnade is less successful in reflecting pedestrian movement patterns.



Layered entry to Life Sciences Annex

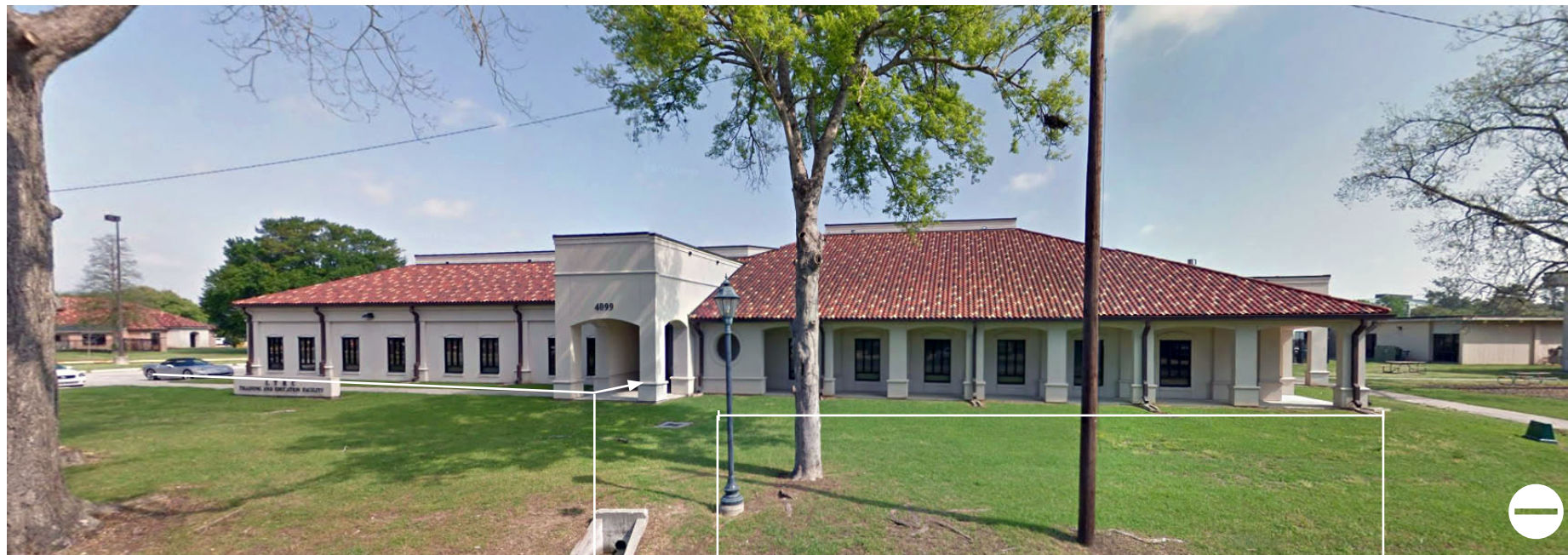

ENTRY SEQUENCE

COLONNADE

LTRC Building







This well-articulated entry to a collection of residence halls utilizes site elements to create gateways and frame views to the courtyard beyond

DESIGN GUIDELINES

PRINCIPLE 4: SOCIAL SPACES

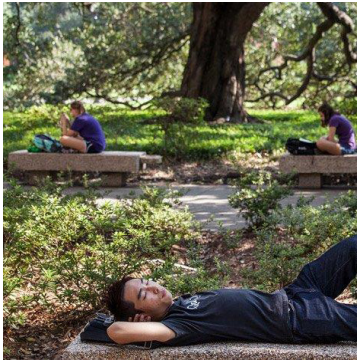
LSU is a campus where academic life happens in public, and the opportunity to share information in social spaces **benefits learning, emotional well-being, and campus culture**. Successful social spaces are programmatically flexible, comfortable, safe, represent varying scales, and allow for quiet and active inhabitation. New construction should create well-defined social spaces with the opportunity to **spill from indoors to out**, convenient to major pedestrian and transportation thoroughfares, and which accommodate activities essential to campus life. Design the ground floor of buildings and surrounding landscape to welcome movement between the two. Exterior communal spaces that serve adjacent buildings should **reinforce information exchange and campus vitality**.

Designers should analyze their project’s surroundings to determine which type of social spaces their project should contribute to the campus. A healthy campus needs diverse **social spaces that vary in program, scale, and edge condition**, with some that bring together diverse disciplines and others that respond to their particular academic setting. While the nature of activities varies, well-designed social spaces connect people to their environment and community. New projects should not negatively impact existing social spaces and should provide new social spaces that integrate into the surrounding campus framework.

	S	M	L	XL
SCALE				
PROGRAM	quiet study intimate break-up space naps	group study class presentations performance	people-watching communication events	exhibitions ceremonies sports
EDGE	BUFFERED / PRIVATE	PERMEABLE BUT REMOVED FROM ACTIVITY	CONNECTED / THOROUGHFARE	OPEN / FLEXIBLE
EXAMPLES				

A healthy campus has diverse social spaces that vary in program, scale, and edge condition. Designers should analyze their project’s surroundings to determine what type of social space their project would best contribute to the campus.

DISTRICT
CONSIDERATIONS

LEARN

SOUTH CORE

- Provide for a broad range of academic activities when adding or redesigning social space.
- Consider the original design intent when designing for the Historic Quad.
- Provide for a broad range of academic activities (ex: research, exhibition, study).
- Prioritize defining the edge of the new quad and incorporate other scales of social space around it.
- Emphasize a transparent, permeable ground floor that allows interior building activity to contribute to exterior campus vitality.
- Design for eating spaces that are flexible, vibrant, public, and support both sitting and getting food to go.

LIVE

- Prioritize casual interaction and recreation (ex: frisbee lawn).
- Provide quiet, private green space with a more intimate, territorial design program than the rest of campus to create a feeling of home.
- Maintain access to and orient social spaces around the lake and Corporation Canal.
- Design for eating spaces that are communal and encourage students to stay and interact.
- Create spaces where students would feel safe out at night with more restricted access, buffered edges, prospect and refuge, and eyes on the street.

PLAY

- Design large scale spaces like parking lots to be flexible for diverse uses, integrate with stormwater management, and enhance the tailgating experience.
- Provide comfortable places to wait for transit off the Nicholson Spine.

DESIGN GUIDELINES

PRINCIPLE 4: SOCIAL SPACES

The landscape design at the Robert Reich Courtyard provides both sun and shade for year-round comfort and softens building edges to provide human scale. The courtyard is a quiet, focused study environment without through-traffic and, at the time of this writing, its NW wall is being removed, which will make the space more visible and accessible to passersby.

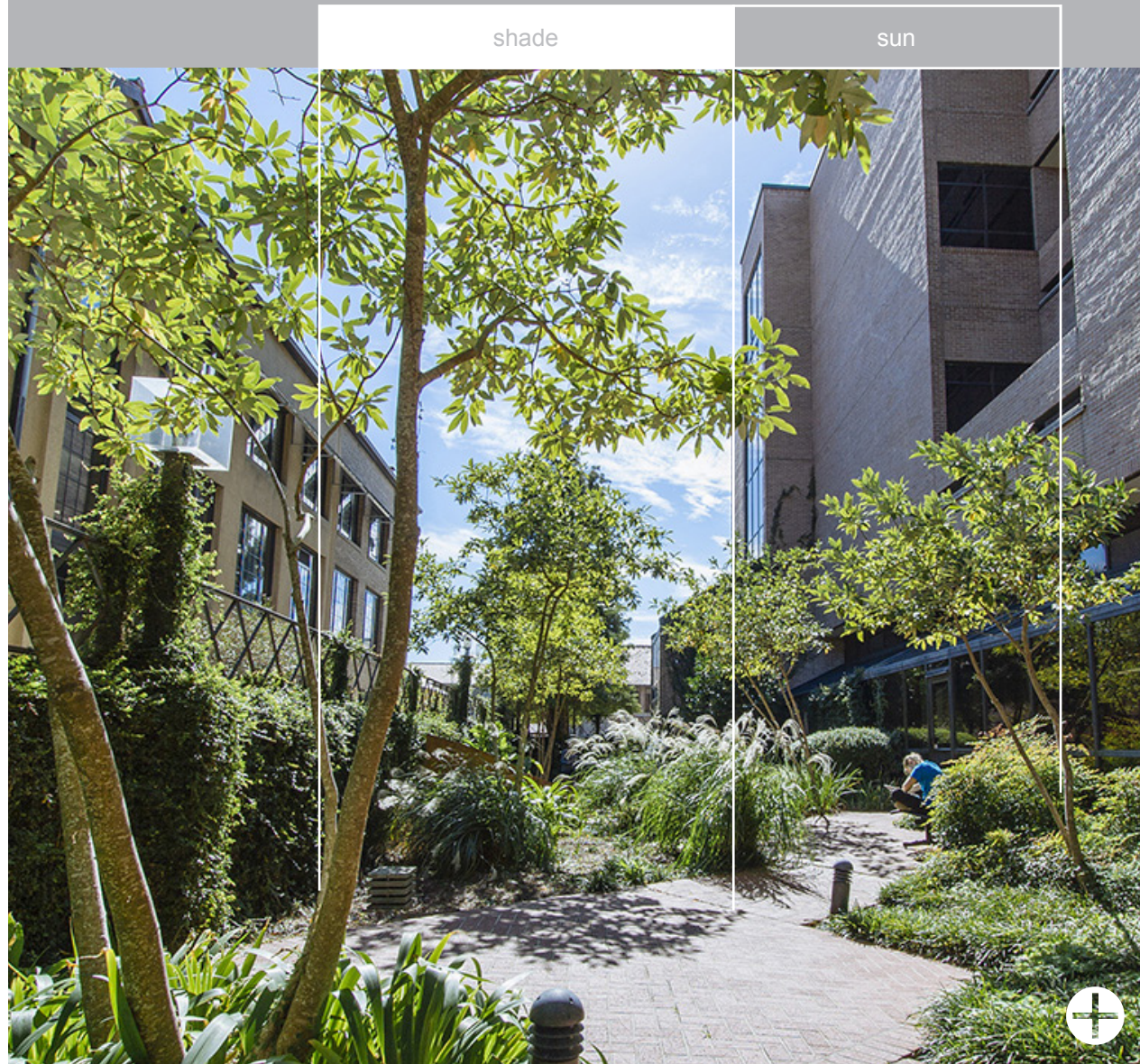

Free Speech Alley brings together a diverse cross section of campus and supports the University mission to exchange ideas. The space benefits from its location on a busy pedestrian thoroughfare and invites congregation by providing comfort with shade and ample seating, some of which is communal on walkway and some of which is protected by landscape. Free Speech Alley is a good example of a loud, vibrant, large-scale social space that provides a variety of campus experiences.

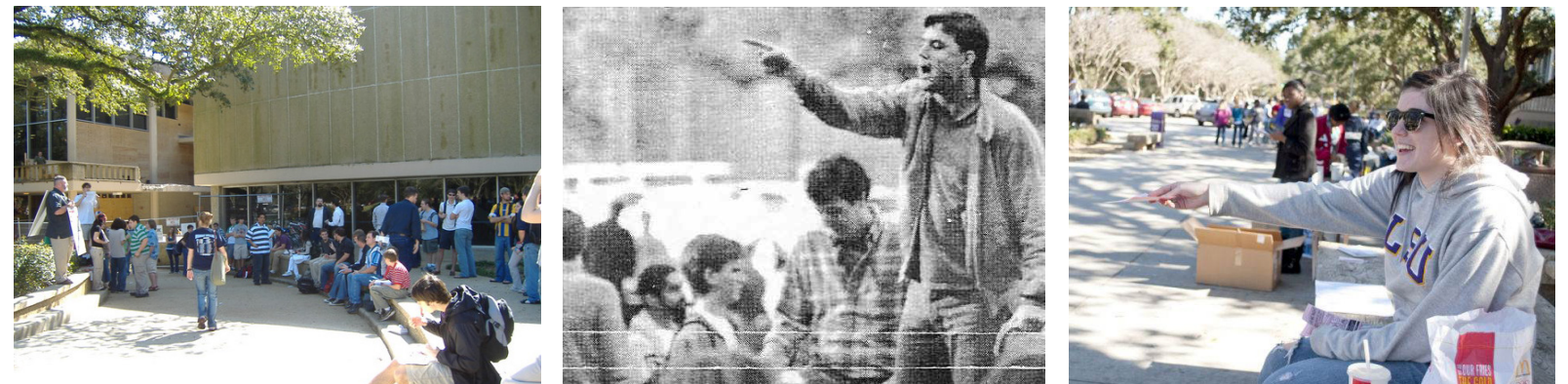
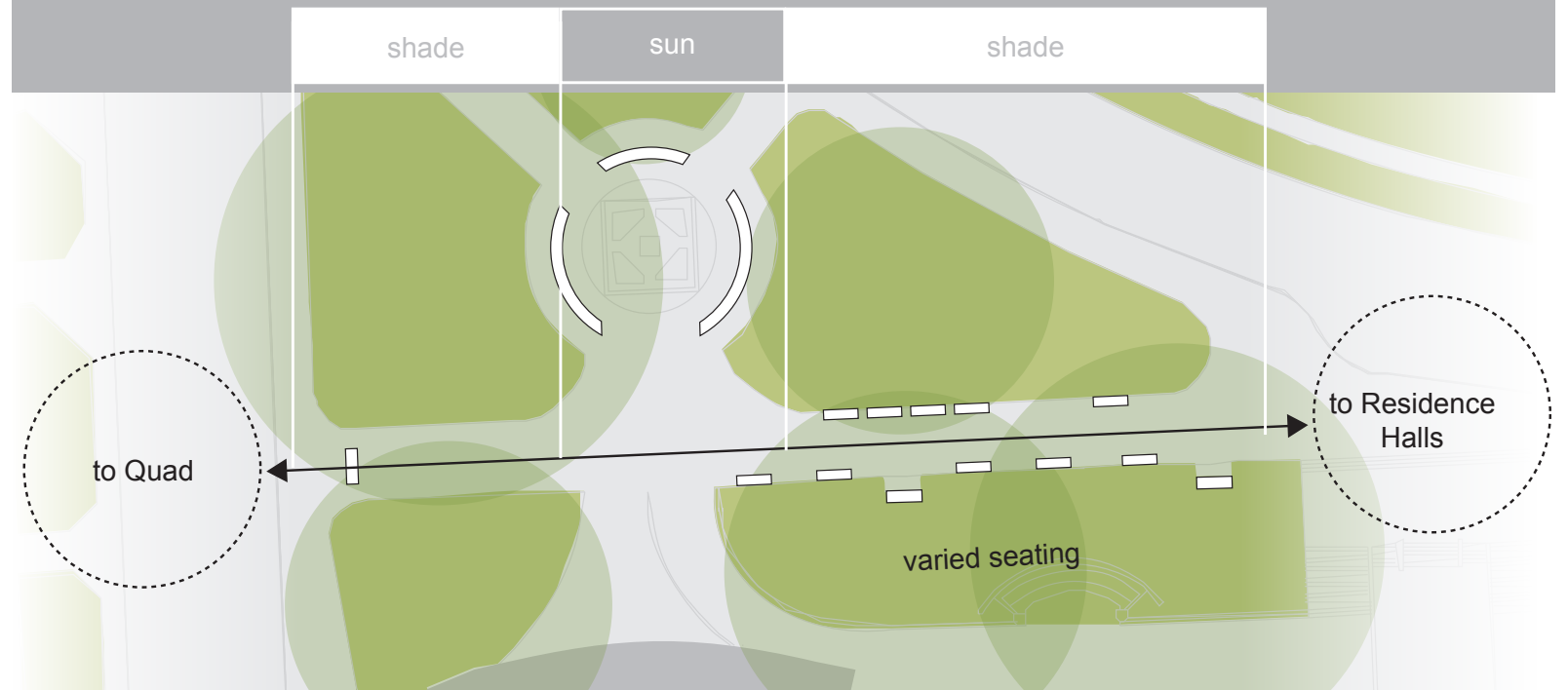

DESIGN GUIDELINES

PRINCIPLE 4: SOCIAL SPACES

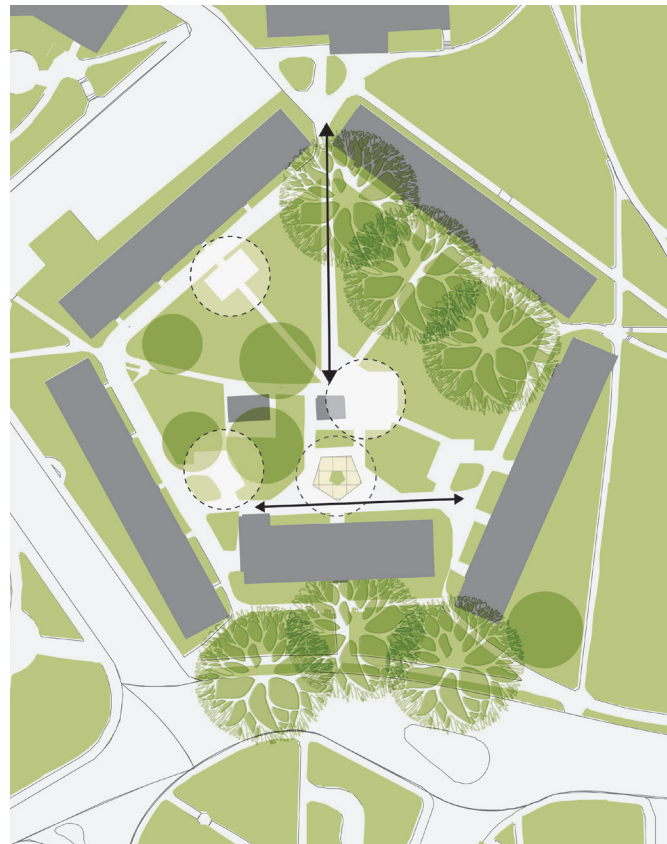

The Pentagon incorporates social spaces with a variety of amenities such as varied seating, shade, and well-integrated landscape. These social spaces reward the time students spend outdoors.



The East & West Campus Apartment courtyards focus primarily on circulation and provide minimal amenities for outdoor gathering.

DESIGN GUIDELINES

PRINCIPLE 4: SOCIAL SPACES



The sunken Murphy J. Foster Hall seating area could be a unique, cozy social space, but it is poorly maintained, does little to buffer the adjacent drive aisle, lacks human scale, has limited relationship with the landscape, and offers insufficient amenities, SUCH AS bike racks, to the people who use it.



By contrast, The seating area at the bookstore is a well-maintained space that offers SOME shade, multiple seating options, connection to landscape, and useful amenities.

DESIGN GUIDELINES

PRINCIPLE 5: HUMAN SCALE

The buildings and landscape at LSU should respect human scale and integrate with the proportions of their context. The historic core provides a good example of human scale, but as the campus grows, contemporary building programs will likely require larger scale construction than historic core buildings, which makes this principle even more essential. **No building should have a blank, continuous, horizontal facade greater than 80' in length** and large buildings should use changes in massing, articulation, overhangs, arcades, transparent glass, and thoughtfully-designed landscape to ensure they do not overwhelm those who move between and through them.

Human scale is not exclusively about the dimensions of the human body but also **touch, sound, and visual perception** of distance. Use transparent glass and light penetration within building interiors to extend visual perception past the barrier of the facade. Design textures, articulation, and mass that can be appreciated at the scale and speed of a pedestrian. New parking garages are envisioned by the 2017 Master Plan and these vehicular structures contribute most to campus when wrapped with pedestrian-oriented uses at the ground floor. Amenities such as small retail areas, bike cages, and coffee shops provide activity, safety and human scale around garages and other large structures.

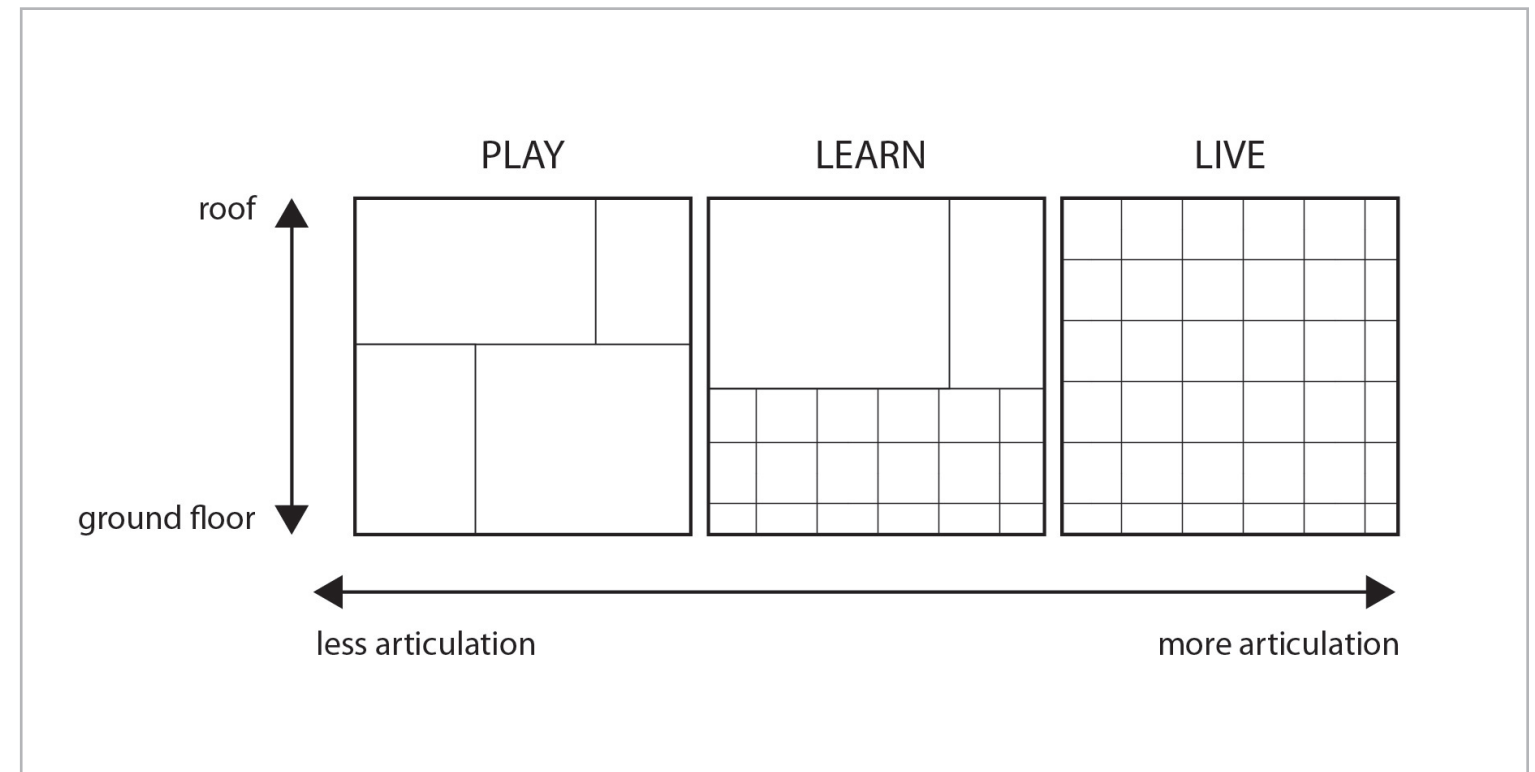

Differing programs across campus will have different design responses to the need for human scale. Large athletic and agricultural buildings can use changes in massing to break down their form and landscape to ground and connect them to context. In the academic districts, where there is a greater need for interaction, knowledge sharing, and public life, the ground floor of buildings should exhibit a high degree of articulation, transparency, and other elements that reinforce human scale.

Residence halls should incorporate the highest level of articulation to create an intimate experience more residential than institutional in nature.

<p>DISTRICT CONSIDERATIONS</p>	<p>LEARN</p>	<ul style="list-style-type: none"> This district sets the standard for human scale on campus. Preserve or augment human scale building elements and landscape when working in the historic core. 	<p>LIVE</p>	<ul style="list-style-type: none"> Prioritize articulation and transparency on the ground floor to reduce the visual mass of buildings. Create an intimate, residential environment with highly articulated buildings. Use landscape to soften the built environment.
<p>SOUTH CORE</p>	<p>LEARN</p>	<ul style="list-style-type: none"> South Academic District buildings can be larger than the Historic Quad, but should function in a similar way, preserving human scale at entrances, linkages, thresholds, and social spaces. Define the edge of the new quad with at least 75% of the building facade. Areas where building facades do not hold the edge should use three-dimensional elements (i.e. arcades) to define it. Buildings on the new quad should be a maximum of 5 stories. New buildings should relate to neighbors using massing, height, and datum lines to create a cohesive building fabric. 	<p>PLAY</p>	<ul style="list-style-type: none"> The monumental nature and open context of this district lends well to human scale through massing change. Avoid high articulation that has little impact and can be perceived as fussy when viewed from afar.

The Digital Media Center is defined by a facade that lacks layered, human scale elements on a site designed for vehicular transportation, while Hill Memorial Library prioritizes the pedestrian experience in its design.

18'

6'

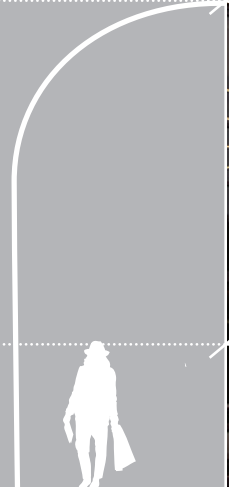

Digital Media Center North Facade



Hill Memorial Library East Facade



Site design with grade change, overhead cover, seating, and areas of prospect and refuge contribute to a campus environment that is comfortable for students, faculty, and visitors.

DESIGN GUIDELINES

PRINCIPLE 5: HUMAN SCALE

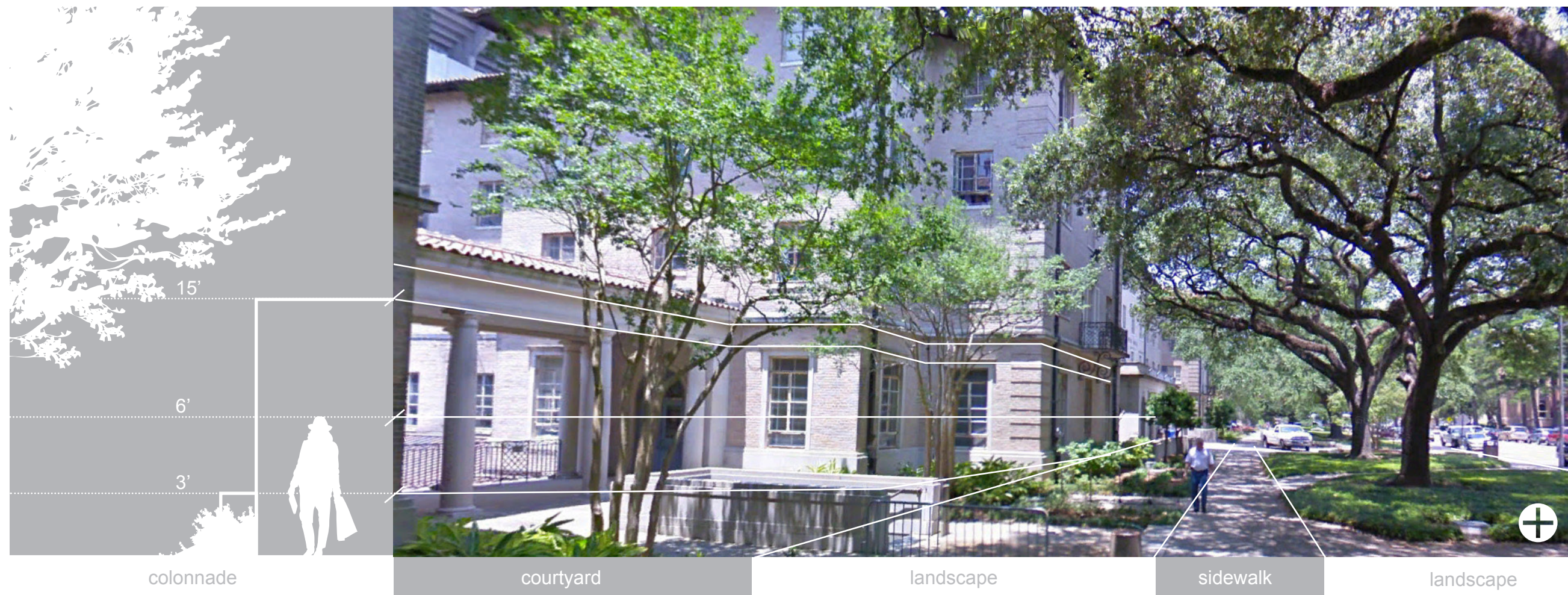

The Hatcher, Johnston, and Hodges Halls provide human scale proportions at the ground floor, ample openings, and fine grain articulation. Landscape layers break up the large building frontage, buffer road noise, and mediate hot sun. The architecture bleeds into the landscape, and vice versa, blurring the lines between one and the other.

It is important to note that the design quality of this place has almost nothing to do with whether the building is an original historic structure or a more contemporary addition to the campus; the intrinsic qualities of good design are indeed timeless.

The original quadrangle carefully positioned fabric buildings in a manner which created human-scaled courtyards for both gathering and movement. Over time, these courtyards were appropriated for use as parking lots, devoid of trees, site features and other human-scaled elements.

Vehicular-scale spaces such as parking lots should be designed to be flexible, accommodate multiple uses, and incorporate human scale. This series of photos was produced by NBBJ for the 2017 Master Plan. The first shows a small parking lot in the historic core currently dominated by a single-use. The next shows its potential redesign with greater landscape integration and human scale amenities such as seating, shade, and a paving pattern that prioritizes bicyclists and pedestrians. The bottom right image shows the same, human-scale environment accommodating parking on game day and commencement in a manner that doesn't preclude its use as a pedestrian space.



DESIGN GUIDELINES

PRINCIPLE 5: HUMAN SCALE

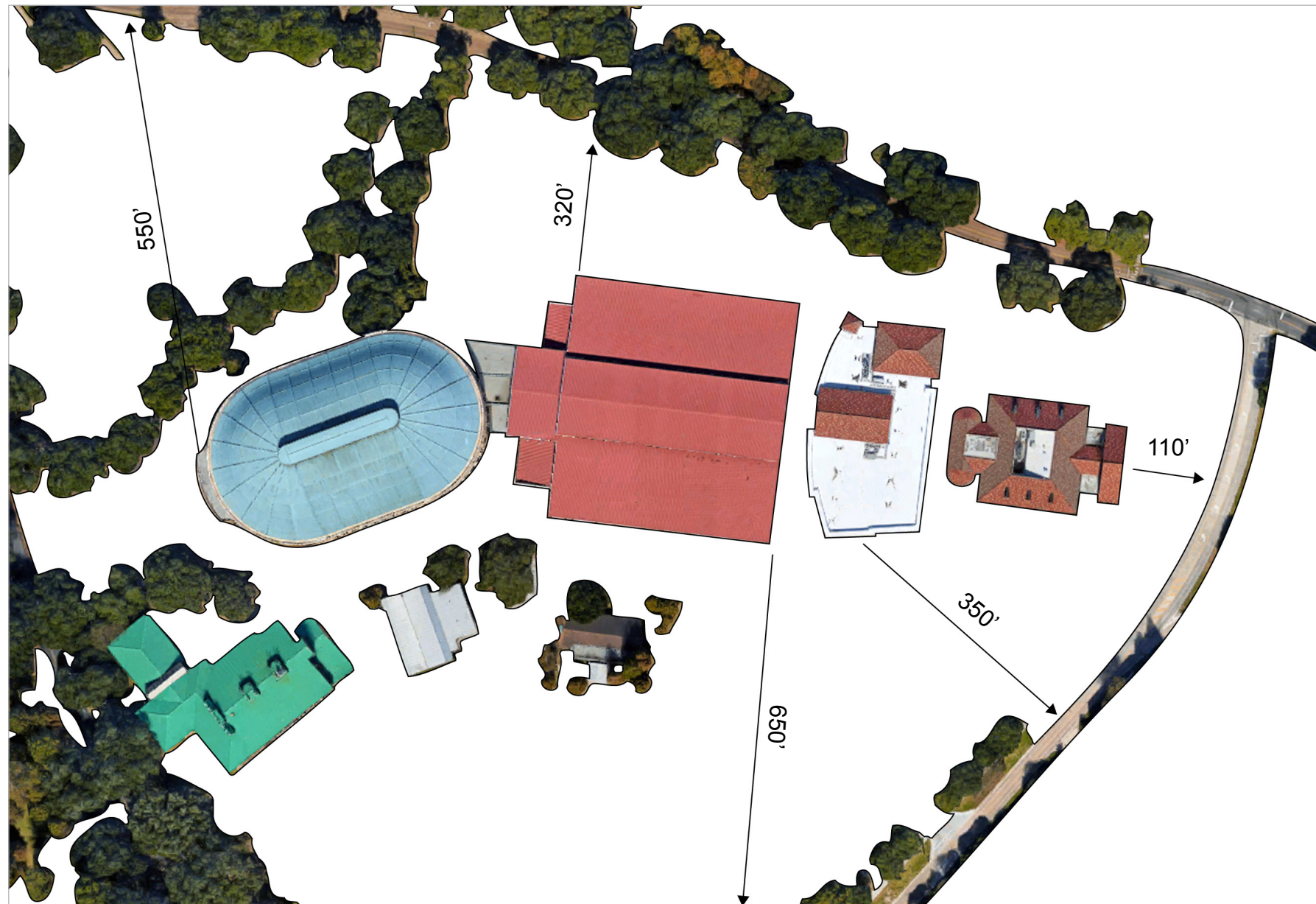

SOUTH ACADEMIC DISTRICT

The site planning around the Parker Agricultural Center, Digital Media Center, and Emerging Technology Center leaves vast distances between the entrances to these buildings and pedestrian circulation routes, creating a scale that discourages walking. The LETC Master Plan supports greater density to transform this district for the future.

ACADEMIC CORE

Building entrances in the Academic Core connect directly to human-scale, pedestrian-oriented circulation. Scattered parking lots and Parade Grounds are exceptions, but not significant impediments.

DESIGN GUIDELINES

PRINCIPLE 5: HUMAN SCALE

The Veterinary School is a large building that employs several strategies to break down its massing to a human scale. Tall vertical stair towers segment the length into a tripartite organization, first floor overhangs bring down the scale of entries, and foreground trees, as well as a row of trees that line the approach, softening the view of the school.



DESIGN GUIDELINES

PRINCIPLE 6: DESIGN ELEMENTS

Allied design elements **contribute to a sense of cohesion, a consistent campus identity, and clear wayfinding** as people experience the architectural language of their environment. The challenge for future designers at LSU will be to bring architecture of different eras, ideologies, and programmatic functions into a unified academic setting and to do so not by rote imitation of historic campus architecture, but by using consistent principles of design.

The Academic Core sets the standard for design elements throughout campus, both because it is the oldest district and because it aligns closely with the goals of the Master Plan. It is walkable, human scaled, well-integrated with the landscape, facilitates social interaction, and provides a beautiful setting for learning. Principles for campus design elements are derived from the core and interpreted for new construction. The principles are grounded in a similar design logic: a warm, muted color palette accented by red roofs and green landscape, medium scale texture, rhythmic articulation, authentic use of materials and construction techniques, and proportions inspired by the core's Palladian geometry. The landscape is included as a design element as well because it is integral to the design expression of the campus.

An overarching goal of new architecture at LSU is **authenticity**. New buildings should eschew false or obfuscating design elements such as partial roofs, artificial arcades, and gratuitous elements. Rather, they should honestly communicate their program, foundation and construction, and utilize an honest and forthright material palette.

Finally, **design elements must meet performative standards of durability and sustainability**. LSU is a campus that has endured over 100 years, and new construction must provide long term durability for many decades to come.

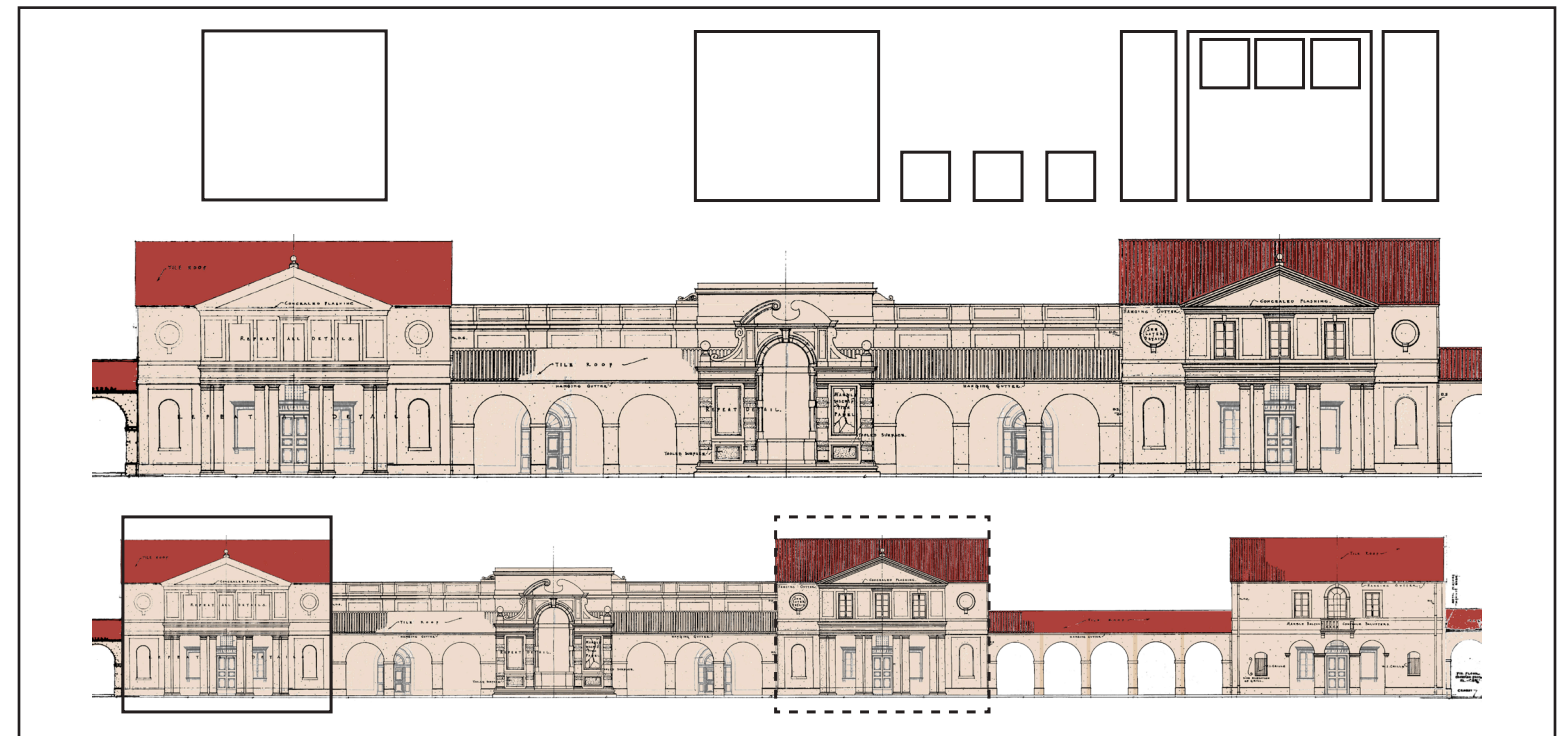

The Academic Core sets the standard for design elements across campus. Its buildings use a muted color palette, simple ornamentation, durable materials, and, Palladian organization in building facades. The symmetry, order, and balance of this organization can be carried forward into contemporary building design to achieve an allied architectural language.

<p>DISTRICT CONSIDERATIONS</p>	<p>LEARN</p>	<ul style="list-style-type: none"> • Design in this district should be the most sensitive to historic material character and articulation. • When engaged in preservation, rehabilitation, restoration, and reconstruction, follow the Secretary of the Interior's Standards for the Treatment of Historic Properties. • New buildings and additions should be respectful of existing historic architecture while differentiating from it. 	<p>LIVE</p>	<ul style="list-style-type: none"> • The district should incorporate design elements reflecting a residential scale versus an institutional scale, in order to look and feel more domestically scaled. • This district should have more finely articulated building elements. • Use landscape elements to provide refuge and soften the impact of new construction.
<p>SOUTH CORE</p>	<p>PLAY</p>	<ul style="list-style-type: none"> • The new technologies and academic programs of the 21st Century will afford opportunities for a more contemporary design aesthetic for this district, as the University's primary growth vector. • New construction can use contemporary design elements applied in ways that relate to the historic core. • Contemporary materials, like precast concrete and curtain wall, are expected and acceptable when they conform with the color, texture, and overall material character of the campus. 	<p>PLAY</p>	<ul style="list-style-type: none"> • The unique aspects of program and scale allow this district to depart from strict adherence to the university's historic architecture. Designers can take the most liberty in their selection and application of design elements, while still tying new buildings to the campus context.

DESIGN GUIDELINES

PRINCIPLE 6: DESIGN ELEMENTS

ROOFS

MATERIAL Terracotta tile roofs cap and protect the original buildings of the academic core. If a new building uses a gabled roof and is near the academic core, it should match this material. A gabled roof further away, in the South Campus for example, should use terracotta or contemporary roofing materials with similar characteristics. Non-gabled roofs can use many types of materials and, regardless of material, a new building's roof must exhibit a high level of **durability**.

ARTICULATION Roofs should be an honest representation of their **construction and massing**; not faux or partial gable roofs. In lieu of these, use contemporary building elements to provide a similar degree of articulation. Shading devices can provide similar articulation as roof eaves when viewed from the ground, and other strategies to signify the top of a building, such as banding and changes in massing, can be used to link contemporary buildings to their historic context.

As the vertical scale of the campus continues to increase, the aesthetic impact of roof design becomes more critical. When the roof can be seen from the ground and surrounding buildings, it should be **designed as a fifth facade** with a material palette and articulation that harmonizes with campus character. Mechanical equipment should be well-integrated into the roofscape and adequately screened from view, including views from taller buildings.

Roofs can further LSU's sustainability goals through employing high albedo materials, rainwater capture, and/or habitat-building vegetation and should meet these performance characteristics while integrating with the campus character.



Historic roof material: terracotta tile



Partial gable roof on the bookstore is not an honest representation of roof construction



Contemporary building programs often require roofs to support copious equipment. Screening this equipment should be more thorough when a roofscape can be seen from the ground and surrounding buildings, and less intensive when the building is tall enough to hide it from view.

DESIGN GUIDELINES

PRINCIPLE 6: DESIGN ELEMENTS



The LSU Life Sciences Annex articulates the building facade with a contemporary eave condition which reinterprets the traditional roof soffits and eaves.



The contemporary eave condition caps the law school addition is a sensitive adaptation of the classical pediment on the Paul M. Hebert Law Center to which it is attached.



The Emerging Technology Center uses a deep eave to shade high windows, and evenly spaced columns and dormers to relate to historic compositional strategies in a contemporary way.

DESIGN GUIDELINES

PRINCIPLE 6: DESIGN ELEMENTS

WALLS

MATERIAL Appropriate materials across campus will be consistent with the historic core in **color, texture, and material character**. Colors are low-contrast, earthy mid-tones without intense saturation or high reflectivity. The mid-scale material texture provides uniformity that creates a backdrop for bright terracotta roofs and lush landscape. Material character should match traditional LSU materials, which are **robust, durable, regionally available, and responsive to the hot and humid Baton Rouge climate**.

ARTICULATION Layer and inset wall elements to emphasize depth and create shadow lines along the façade. New construction at LSU should reinforce the historic campus character of articulated building elements in **rhythmic repetition**, inspired by the bilateral symmetry and hierarchy inherited from the Palladian organization of the historic core. Historic campus buildings use an intermediate, **human scale** in wall articulation which new buildings should emulate. Broad, smooth, or bulky building elements are not commensurate with LSU’s architectural character.

Fine articulation of campus buildings is often achieved in the detailing of elements such as windows, doors, pediment, and base, with greater detail establishing hierarchy at key points like entrances. The ornamentation is often subtle, understated, and contributes to a **unified building character** that knits together varying programs and spaces. New buildings should consider contemporary building elements to integrate rhythm, repetition, human-scale articulation, and subtle ornamentation to create a cohesive language across campus.



COARSE AGGREGATE STUCCO

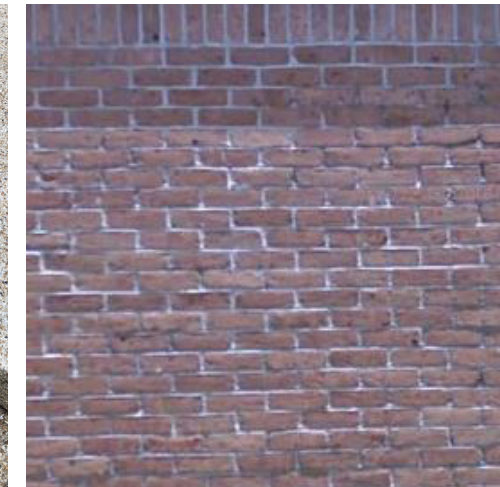

DUSTY RED BRICK

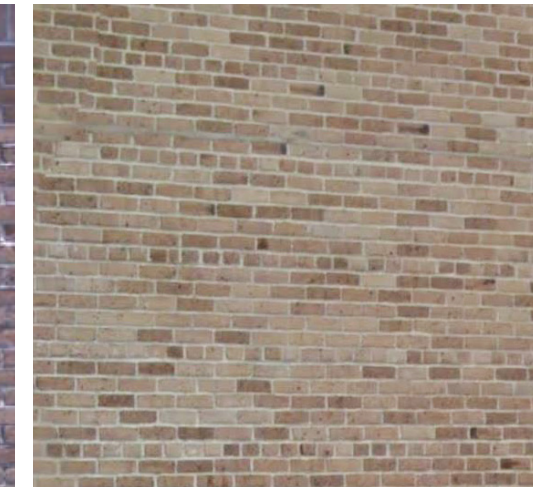

ST. JOE BRICK

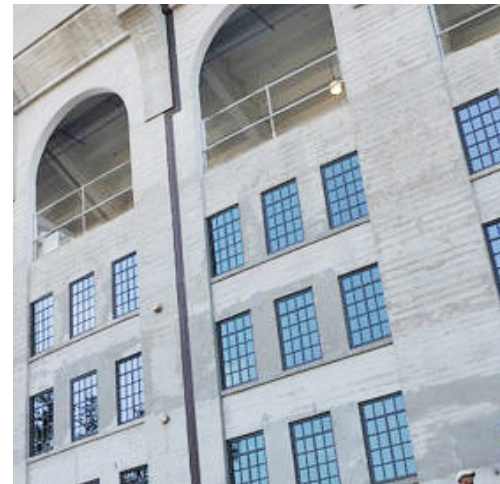

CAST-IN-PLACE CONCRETE

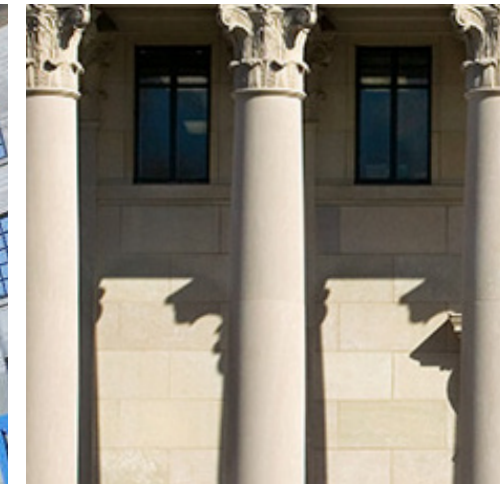

STONE

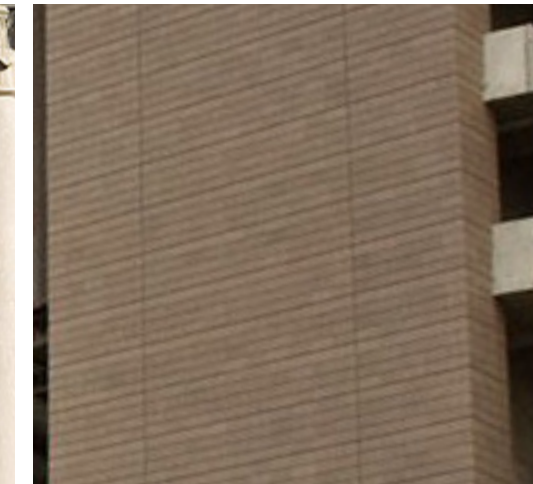

TERRACOTTA TILE



PRECAST CONCRETE



ARTICULATED PRECAST



BRICK/PRECAST BLEND

historic campus buildings invoke
"harmonically repeating geometric
order" - J. Michael Desmond



Coates Hall +

deep openings emphasize visual weight and permanence

create shadow lines on the facade



Tiger Band Hall +



The Gym Armory building top is a well articulated composition without a visible roof or eaves. Ornament here is organized around wall elements to provide a solid, mid-scale texture.



Foster Hall's ornament is organized around building elements such as the door entry, window, and roof eaves, with greater detail establishing hierarchy at the entrance.

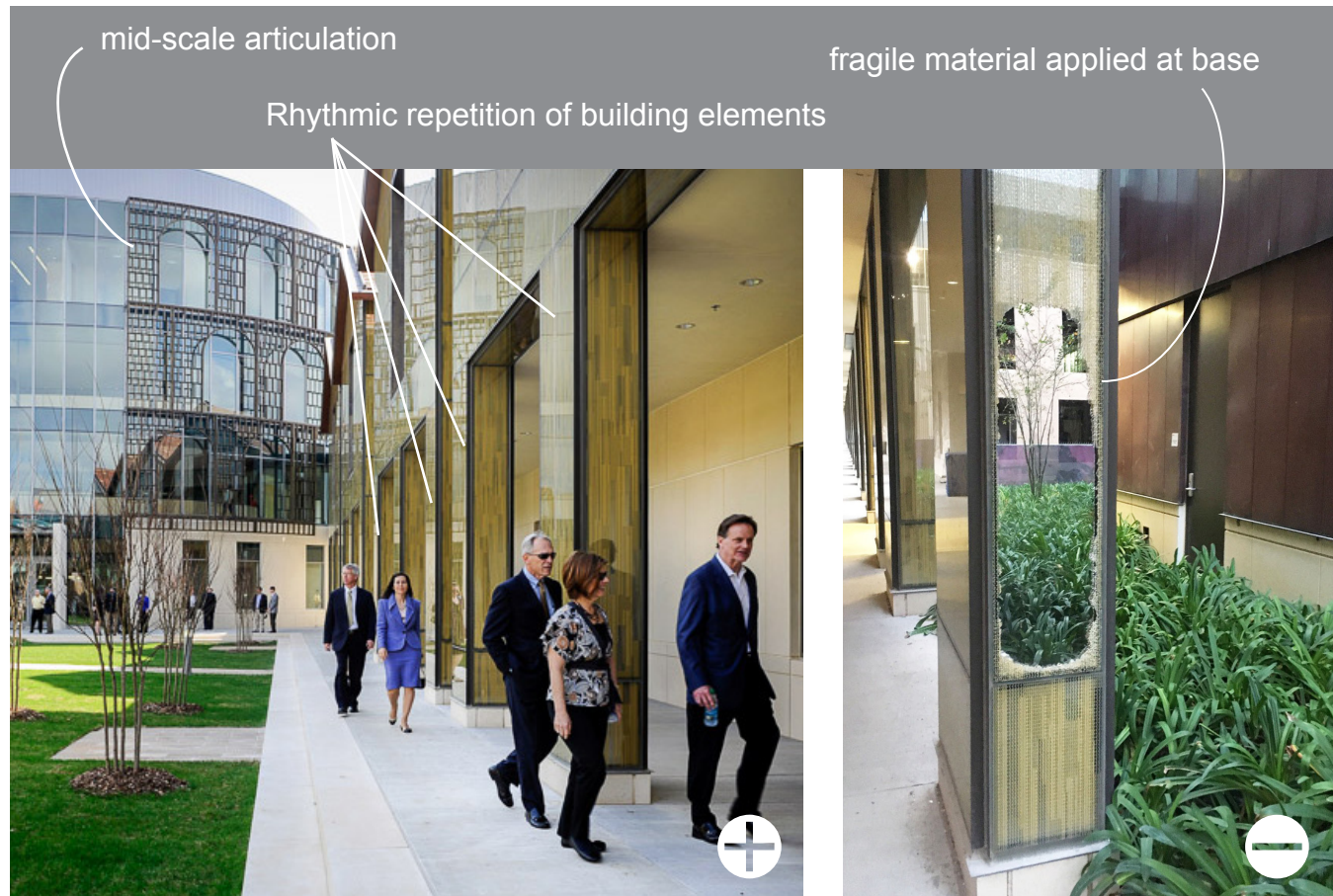

Glass walls at the Business Education Complex adapt historic articulation to contemporary design, but lack the performative characteristic of durability



The south facade of Choppin Hall lacks human scale articulation



Campus buildings must stand the test of time with durable materials that demand minimal maintenance.



Mechanical equipment should be screened from view, especially on pedestrian thoroughfares.

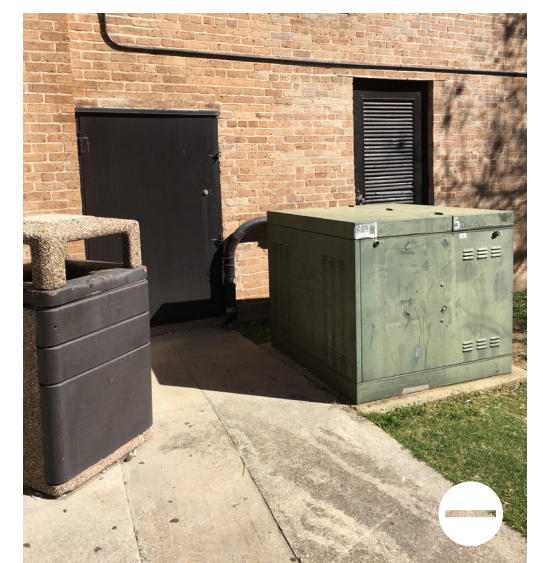

DESIGN GUIDELINES

PRINCIPLE 6: DESIGN ELEMENTS**OPENINGS**

MATERIAL Glass should be transparent so that activity within buildings is visible, accessible, and reinforces the richness and vitality of campus life. This is especially important in connecting interior and exterior social spaces. Prioritize solar control which effectively shades, but does not obscure windows.

Avoid the “blank stare” of a building façade where dark mullions and dark glass merge into a large, opaque field. Windows and curtain walls should use light mullions that contrast with glazing to break fields of glass into a smaller scale.

ARTICULATION J. Michael Desmond describes the organization of openings in LSU’s historic core as possessing “an almost musical cadence” inherited from their Palladian organization. These buildings exhibit bilateral symmetry and establish a clear hierarchy with an opening always located in the center. The rhythmic organization of these openings can be carried forward into contemporary building design to achieve an allied architectural language that spans different eras and building programs.

Windows should be optimized in size and orientation to provide abundant views and daylight to interiors. **Prioritize shading elements that do not obscure window transparency** - such as overhangs, shading devices, layered facades, and protective landscape - as opposed to dark glass or window shades.



Transparent glass at the Student Union connects interior activity with outdoor campus life.



Openings are organized with “an almost musical” bilateral symmetry and a hierarchy inherited from palladian geometry.



Similarly colored glass and mullions occur at the bookstore. This example could provide a finer grain of human-scale articulation with clear glass, light mullions (like the Student Union shown above right), and / or layering to articulate the facade. This facade will improve as its landscape matures.

Consider the opportunities for articulation of large curtain wall expanses with vertical and/or horizontal mullion patterns.



Dark glass at the Digital Technology Center separates interior building activity from exterior surroundings and merges with dark mullions to create a large, opaque field. This contrasts with the articulation utilized at Patrick Taylor Hall.

Consider "fine grain" articulation of openings, utilizing sunscreens and other window fenestration



The Reilly Theatre uses light mullions to segment a large field of glass and provide intermediate articulation that relates this large building to the historic core.

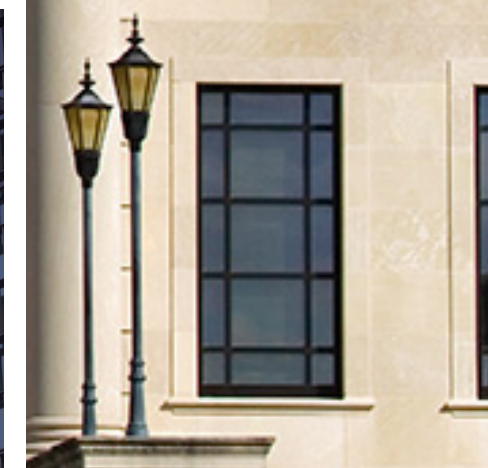
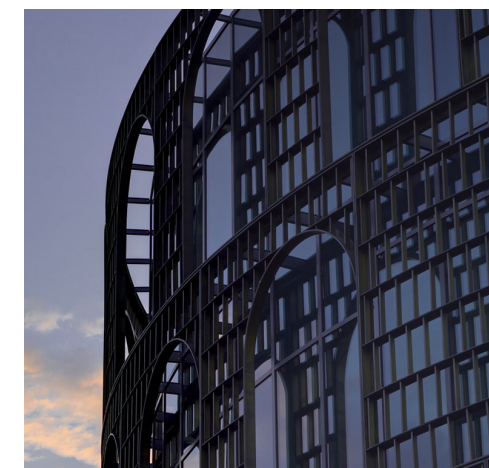
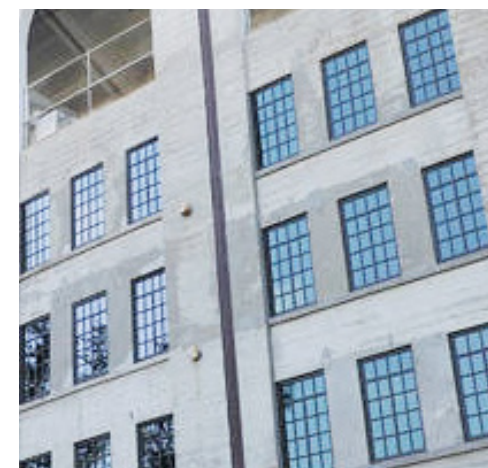
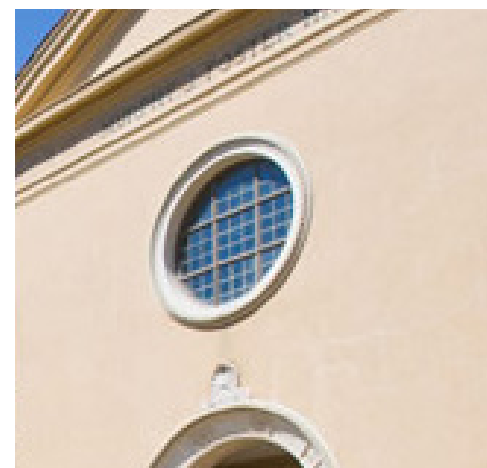
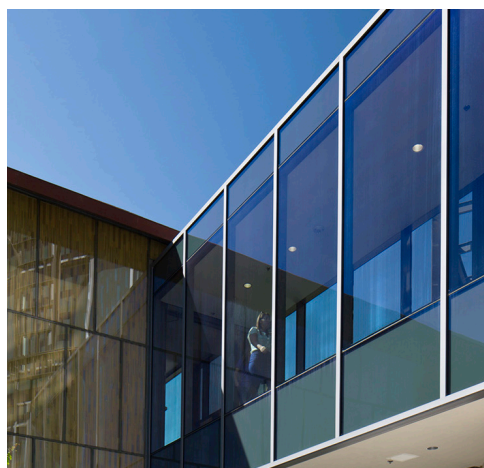

Across campus, window mullions break up expanses of glazing to greater or lesser degrees.

DESIGN GUIDELINES

PRINCIPLE 6: DESIGN ELEMENTS

LANDSCAPE

Landscape design can serve as the “connective tissue” across the campus, not only enhancing the linkages and layering of campus buildings, but also creating aesthetic continuity between buildings of varied scale, character and typology.

Vegetation should thoughtfully define and frame flexible open space, mediate building scale, and provide shade, all with topographical context and maintenance requirements in mind. Together, material consistency and circulation hierarchy can establish a connective and clear network that respects distinct districts without compromising Master Plan framework systems. All designs should be sensitive to the role of water on campus, incorporating multiple stormwater management tactics at a range of scales.

CANOPY The ubiquitous, mature Live Oak canopy is one of the most defining features of LSU’s campus. Aside from providing much-needed **shade** between buildings, the canopy gracefully reaches to the ground, **framing and defining** important open spaces, and providing a backdrop to much of the activity on campus. With the addition of a diverse and **native** palette of canopy trees, LSU has the opportunity to expand this extensive network, reinforce movement with shaded walks and highlight new campus spaces and hubs of activity. As the campus redevelops in key areas and grows to the south, canopy should be used to mediate the scale of larger buildings and reshape open space, making new areas of campus comfortable for pedestrians.

GARDEN Gardens on campus are expressive of a vibrant plant palette, consisting of a combination of **native and adapted plants**. While gardens can be an effective way to further break down scale, creating more intimate gathering spaces throughout the campus, they should be implemented with restraint as they require special care and additional **maintenance**. When used carefully, such as under large Live Oak canopy where other plants may not be viable, gardens can be a successful design element.



Canopy frames and forms a backdrop for the Parade Ground, a continuous, uninterrupted lawn that supports a range of activity.



Trees ineffectively used to provide shade or mediate scale.

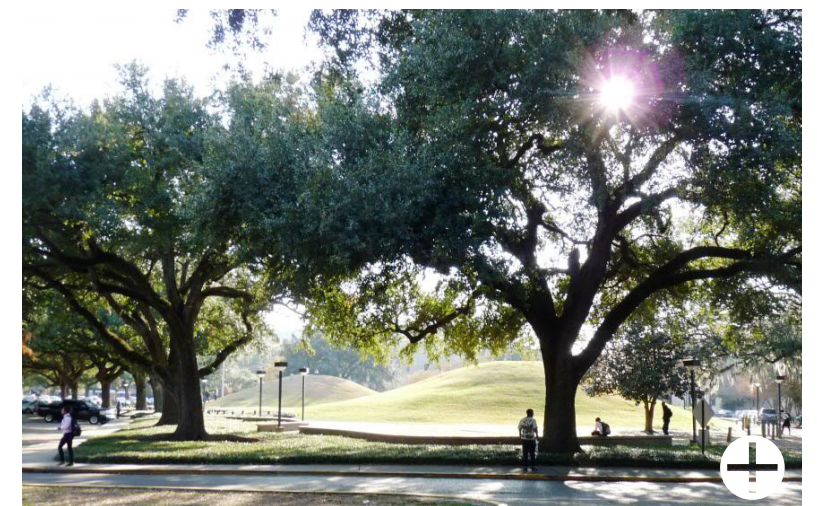

Shade and adequate paths reinforce movement through the campus.

LAWN Serving as a unifying feature, lawn is an essential component of the campus fabric upon which new development is sited. It provides both an inherent **durability** and **flexibility** in order to support many user groups and a range of activity - from tailgating to frisbee to study groups.

CIRCULATION Paths and roads, whether they are pedestrian, vehicular, bike, or some combination, should provide **comfortable, safe and efficient routes** for people to move through campus. This can be accomplished by incorporating a clear **hierarchy** of size and path types that link spaces and relate to building entrances. **Consistency in materials** tie together disparate spaces that may vary in size, character, or program.

FURNISHINGS Seating, signage, and bike parking should be **clear and efficient but recede** within the campus landscape. When appropriately located along a central circulation spine or outside a main building entrance, furnishings reinforce **circulation**, activate **gathering spaces**, and provide **safety, comfort** and **security** to LSU students and visitors.

TOPOGRAPHY The **Highland Ridge** played a major role in the siting and structure of the historic core, serving as the primary organizing feature. Future building and landscape projects should carefully consider this natural change in topography. The designation between “**highland**” and “**lowland**” has implications on soil type, plant palette, and stormwater management techniques.

WATER From the Mississippi River to Corporation Canal and the campus lakes, water has a major presence on the LSU campus. Future development, especially in the lowland, necessitates a purposeful and thoughtful engagement of **stormwater management practices** to not only collect and move water during and after storm events, but to transform the capture and treatment of stormwater into a **amenity** for the campus. To be effective, this process needs to take place at a range of scales - from developing a series of small swales along campus roads that slow water before entering larger detention areas for storage, to the **restoration** of canals to allow for drainage and a more productive local ecology.

For more detailed landscape requirements, refer to the Campus Landscape and Site Design Standards 2017.

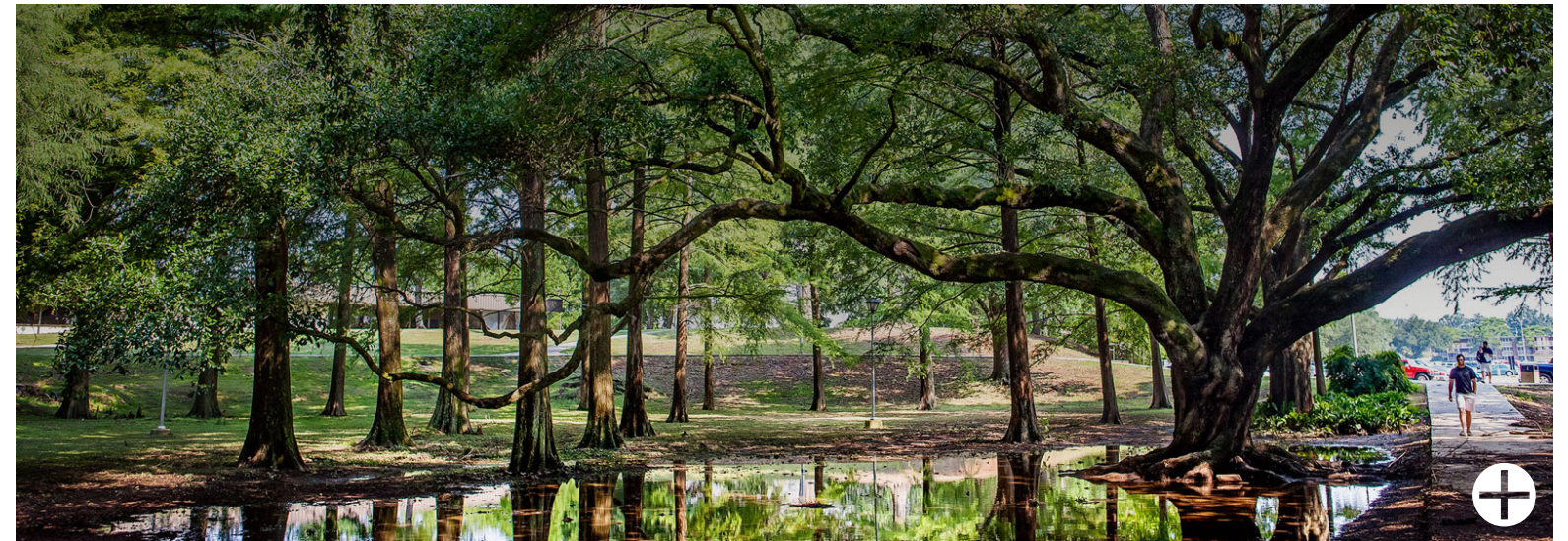

Plant selection relates to topographic and soil conditions in low, wet areas of campus.



Canopy effectively frames views in this historic core, and provides much-needed shade.

Parking encroaches on Corporation Canal, a single function drainage way. The opportunity exists to restore the canal for increased ecological function and recreational uses.



DESIGN GUIDELINES

PRINCIPLE 7: SUSTAINABILITY

LSU is committed to producing not only high-performing academic and athletic institutions, but environmentally sustainable ones as well. Valuing environmental performance positions LSU as **resilient, cost-efficient, rooted in its context** and, most importantly, invests in LSU’s most important resource—its people.

The buildings of the historic core provide climate-adapted examples that control the sun, preserve access to breezes, manage stormwater, and stand the test of time. Emulate and combine these functions with high-performance mechanical systems and flexibility to maximize sustainability on campus. New construction should meet the guidelines in this document, a **30% energy reduction from current code**, and 25/40 points on the LSU sustainability checklist. Refer to 1.5 Sustainability for more information on building-level sustainability requirements.

Health is a key component of a high-performing campus and buildings should optimize thermal, visual, and acoustic comfort as well as occupant-control.

New projects should incorporate best management practices for permeable surfaces, stormwater collection and storage, and self-sufficient, climate-appropriate plantings to meet the challenge of Louisiana’s extreme weather events. **Celebrate stormwater** with visible and attractive components of a large-scale stormwater management system.



The campus and Baton Rouge community are particularly sensitive to the effects of climate change. New design should center LSU as a leader in energy efficiency, climate adaptive response, and resiliency to support its people for a changing future.

<p>DISTRICT CONSIDERATIONS</p>	LEARN	<p>SOUTH CORE</p> <ul style="list-style-type: none"> • Sustainability and historic preservation are not mutually exclusive and increasing energy efficiency is encouraged in both renovations and new construction. • Incorporate energy efficiency and sustainability without negatively impacting the aesthetic character of the district. 	<p>LIVE</p>	<ul style="list-style-type: none"> • Prioritize health and well-being • Encourage active mobility that includes walking, stairs, biking, etc. • Celebrate stormwater infrastructure
	PLAY	<ul style="list-style-type: none"> • This district should highlight architectural and landscape sustainability elements, making them visible teaching tools across campus • Encourage active mobility that includes walking, stairs, biking, etc. 		<ul style="list-style-type: none"> • Design buildings with programmable occupancy so they can conserve energy when not in use • Encourage active mobility, especially bike commuting along the Nicholson Spine

DESIGN GUIDELINES

PRINCIPLE 7: SUSTAINABILITY

long, thin floorplate allows for optimum daylighting

shading devices on the south facade

connection to landscape with courtyards

self-shades the north facade

photosensors turn off lights when daylight illuminates space

Cypress Hall uses shading devices on the south side, self-shades on the north side, and is oriented east-west for maximum solar control. Its massing is split into three towers and incorporates five courtyards to provide well-daylit interiors and connection to the landscape.

DESIGN GUIDELINES

PRINCIPLE 7: SUSTAINABILITY



Choppin Hall does not consider daylighting and energy efficiency in its design. The small, unshaded windows contribute to glare on the interior and building orientation does not respond to climate.



The east facade of the Chemistry and Materials building uses a large amount of unshaded glass, increasing the building's heating load on hot summer days.

A narrow floorplate and tall window glazing provides ample, even daylight for classrooms in the University Medical Building at the LSU Medical Center in New Orleans. Designers should aim for a height to width ratio of 1:2 for classroom spaces, where the width of a classroom is no greater than twice the height of its window glazing, to provide quality daylight. If designers employ light shelves, they can increase their height to width ratio to 1:2.5, while skylights, re-light windows, and other daylight augmentation can increase it even farther.

height of glazing



width of classroom



DESIGN GUIDELINES

1.5 SUSTAINABILITY

LETTER FROM CAMPUS SUSTAINABILITY

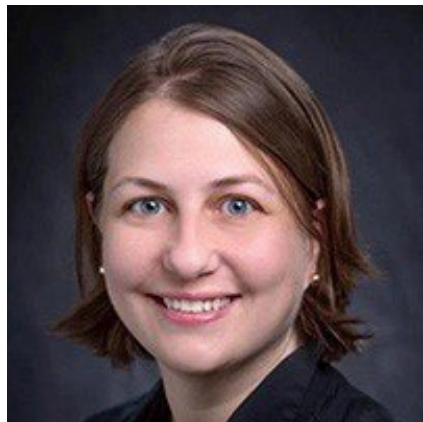

At LSU, we believe that a successful sustainability program depends on all facets of the LSU community – students, who challenge and inspire us with new ideas and innovations; faculty, who conduct sustainability-related research and instruct the next generation of leaders; and staff, who manage the daily operations of our entire campus. LSU students originally requested the creation of a Campus Sustainability unit in 2008 to ensure that the university reduces its carbon footprint, offers courses with an environmental focus and provides education and awareness of sustainability issues and practices. In early 2017 Campus Sustainability conducted a sustainability literacy survey, which was completed by more than 500 students, and found that 65% of prospective college students consider the existence of a sustainability program to be “important” or “very important” in selecting a university to attend -- meaning that sustainability plays an important role in recruitment

and retention of students. To that end, LSU has committed to increased sustainability in campus operations, addressing such areas as greenhouse gas emissions reduction, energy and water conservation, waste reduction and recycling, building renovation/new construction, and public education and outreach.

All stakeholders, as well as visitors to the university, benefit from the remarkable natural beauty of the campus live oaks and lakes. LSU recognizes the role sustainability plays in protecting these natural resources for future generations of LSU students, faculty, staff and visitors. The Sustainability section that follows demonstrates this commitment and sets goals and objectives that are in line with the ones established by the Campus Committee on Sustainability. The success of the Campus Sustainability program is illustrated by initiatives such as improving GameDay recycling, partnering with the Baton Rouge Area Foundation to create a campus bike share program, passing a Student Sustainability Fee to fund sustainability-related projects, implementing a “Refills not Landfills” program to reduce the waste generated on campus, and installing Bigbelly solar-powered waste receptacles on campus.

LSU has won five Louisiana Department of Environmental Quality Leadership Awards, two National GameDay Recycling Challenge awards, five Tree Campus USA awards, Bicycle Friendly University designation at the silver level. LSU has also recently received

designation as a US Department of Education Green Ribbon School, and has received numerous Keep Louisiana Beautiful grants. While LSU has made remarkable progress, there are even more opportunities to improve campus sustainability. Although colleges and universities across the U.S. are only responsible for about 3% of the total greenhouse gas emissions emitted by the United States, LSU has a responsibility to educate future leaders on the environmental and economic benefits of sustainability initiatives. The strategies identified in this plan will help ensure that LSU emerges as a leader in sustainability in Louisiana, nationally and internationally.

SARAH TEMPLE
Manager
Campus Sustainability

TAMMY MILLICAN
Executive Director
Facility & Property Oversight

DESIGN GUIDELINES

SUSTAINABILITY

Sustainability is integrated into the design guidelines in a multitude of different methods. First, sustainability is memorialized as the 7th guiding design principle, as described earlier in this document. This sets the tone for how the climate responsiveness, energy efficiency, and health are intertwined with the way designers should think about the campus. The diagram to the right describes how the Campus Committee on Sustainability’s existing framework coincides with the seven design principles. All but the initial design principles on Time and Place address issues and concerns set forth by each of the six subcommittees. Next, this section advances logistically how sustainability should be integrated into the campus master plan and building projects moving forward in three primary ways:

- 1. Building Level Requirements** – this section outlines what requirements design teams should submit during the project approval process.
- 2. Benchmarking and Goal Setting** – documents benchmarks and metrics derived from a series of LSU peer comparisons around the Association for Advancement of Sustainability in Higher Education’s (AASHE) sustainability framework.
- 3. Campus Committee on Sustainability Integration** – builds upon and lists the goals and strategies created by the committee, relates them to the AASHE benchmarking analysis, and maps opportunities for integration into the Master Plan framework.

CCS CATEGORIES	ENERGY EFFICIENCY & GREEN BUILDING	TRANSPORTATION	WASTE REDUCTION & RECYCLING	PROCUREMENT	LANDSCAPE & GROUNDS	FOOD
DESIGN PRINCIPLES						
PRINCIPLE 1: TIME & PLACE						
PRINCIPLE 2: LINKAGES						
PRINCIPLE 3: LAYERING						
PRINCIPLE 4: SOCIAL SPACES						
PRINCIPLE 5: HUMAN SCALE						
PRINCIPLE 6: DESIGN ELEMENTS						
PRINCIPLE 7: SUSTAINABILITY						

DESIGN GUIDELINES

SUSTAINABILITY

BUILDING LEVEL REQUIREMENTS

The building level sustainability requirements are designed to ensure a minimum standard of performance is achieved for all projects, while also providing requirements for projects designated to feature sustainability. Feature projects are identified by the Campus Planning and Oversight Committee (currently FDDC) during the concept phase review (refer to Governance section for additional details). These requirements build upon the State of Louisiana's laws already in place for public projects, namely revised statute 40:1730.49 and the Energy Policy Act of 2001. However, this document describes their use in the LSU project approval process for all campus buildings regardless of state oversight.

MINIMUM REQUIREMENTS FOR MAJOR CAPITAL PROJECTS

For all new construction and major renovation projects greater than 5,000 square feet, the following requirements must be met:

- Using the custom FP&C Environmental Building Systems Checklist, attain at least 25 points. At least 2 points must be obtained from Section 6 – Water Use Efficiency and at least 6 points from Section 7 – Energy Efficiency category. The checklist utilizes the ASHRAE 189.1 2009 framework as a guideline for requirements. A copy of the checklist can be downloaded [here](#).
- Install building-level submetering of major fuel types to allow for energy benchmarking
- During the Schematic Design Phase CPOC review, submit a completed FP&C checklist with accompanying narratives of how pursued points are integrated into the building design.
- During the Schematic Design Phase CPOC review, submit written narratives of how the design engages each of the 7 design principles. Narratives should be up to 250 words per design principle.

ADDITIONAL REQUIREMENTS FOR FEATURED SUSTAINABILITY PROJECTS

For projects identified by the CPOC as being a feature sustainability project, the minimum requirements above must be met in addition to the following:

- A total of 35 points must be obtained from the FP&C Environmental Building Systems Checklist
- Compliant energy modeling software as prescribed by ASHRAE 90.1 Appendix G must be used to show an energy cost savings of at least 30% over current state energy code.
- 3rd party environmental certification must be achieved in at least one of the following programs: LEED v4 (minimum level of certification = silver), Sustainable Sites Initiative, WELL Building Standard, Living Building Challenge (petal certification acceptable), Passive House, or any other program suggested by the design team and approved by the CPOC.
- A 250-500 word narrative must be submitted for the Schematic Design Phase CPOC review that describes which certification program the project is attempting and how, including any feasibility analysis such as preliminary LEED checklists, cost analysis, etc.

DESIGN GUIDELINES

SUSTAINABILITY

BENCHMARKING AND GOAL SETTING

Establishing metrics, benchmarks, and goals is an important part of integrating sustainability into the master planning process. The act of discussing and documenting metrics provides a structure for accountability over time, while benchmarking helps to calibrate expectations and set goals for the future. The Association for Advancement of Sustainability in Higher Education (AASHE) has created a self-reporting framework for colleges and universities to measure their sustainability performance, named the Sustainability Tracking Assessment and Rating System (STARS). The point-based system covers everything from grounds management, to building efficiency, and even to curriculum integration, and universities can receive a bronze through platinum rating. In 2012, LSU received a silver rating under the V1 of the program, and is currently working on submitting for certification under the latest 2.1 version.

To help guide the Campus Committee on Sustainability’s (CCS) efforts around goal setting, key metrics were taken from the AASHE STARS framework and added to the six CCS sustainability categories. Data was then aggregated from the STARS website to help inform the 2030 targets, including LSU’s peer public institutions from primarily the SEC conference, and a national average of the other 280+ STARS universities.

The following sections report the results of this process, broken up by the six CCS sustainability categories. Each section reports key targets derived from the benchmarking analysis, including a list of CCS strategies to achieve them. Finally, the strategies that intersect with the space planning from the overall Master Plan are diagrammed as potential areas of opportunity for the LSU facilities team and designers to consider moving forward.

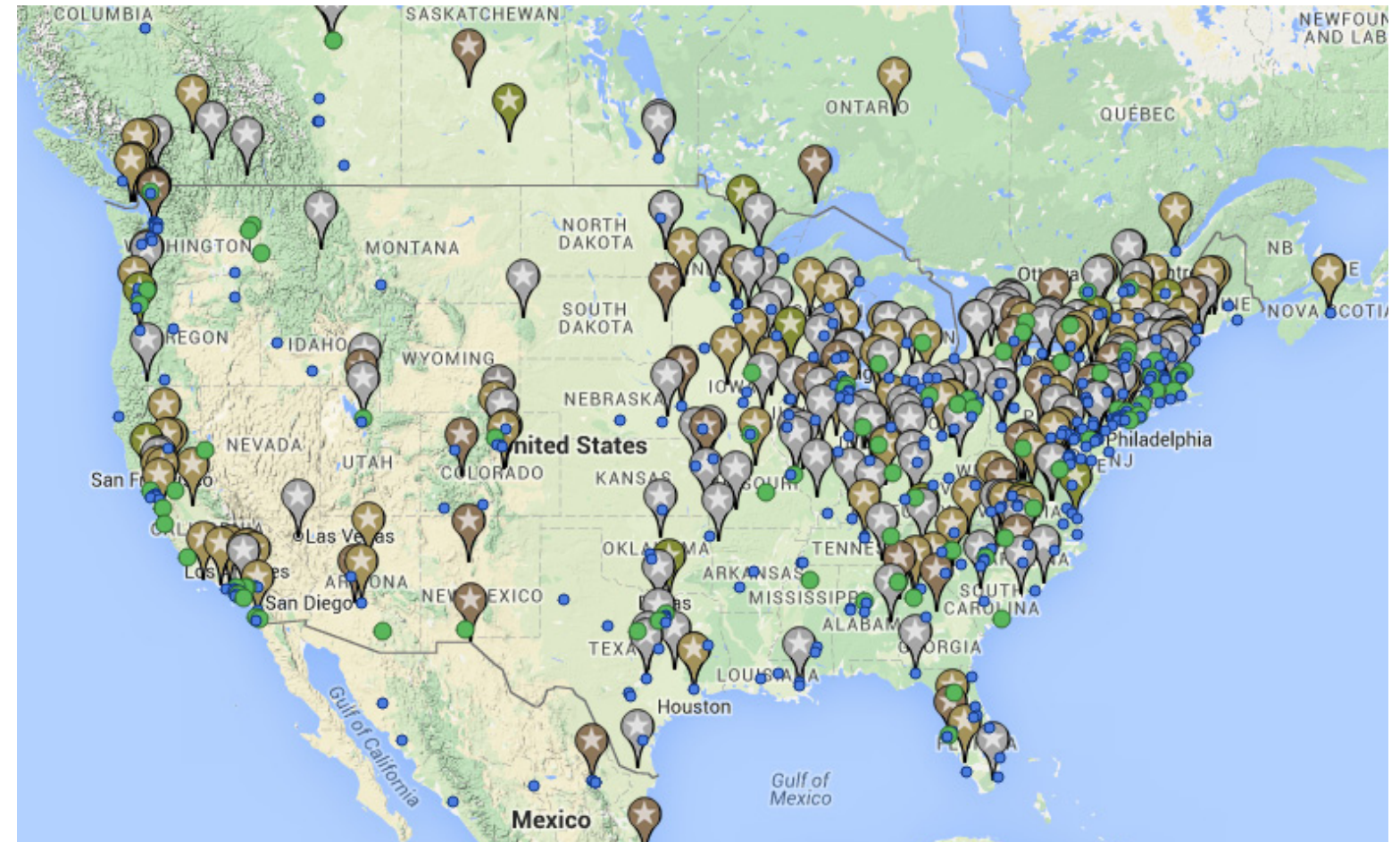

MAP OF UNIVERSITIES PARTICIPATING IN AASHE’S STARS PROGRAM



DESIGN GUIDELINES

SUSTAINABILITY

ENERGY EFFICIENCY AND GREEN BUILDING

As the flagship university in Louisiana, LSU strives to be a clear leader in energy efficient building design. Lower energy use ultimately translates to a lower bottom line and a more efficient use of taxpayer resources. These types of high performance buildings also protect the environment while enhancing the learning environment for its students. LSU’s goal for a campus wide energy use intensity is 104 kBtu/sf-yr, which would position it as a top performer amongst its peers.

GOALS FOR 2030

- Increase **energy efficiency by 40%** on campus based on the 2012 baseline
- Generate **5% of campus energy** from renewable sources on campus
- Purchase at least **10% of campus energy** from renewable sources

STRATEGIES (*italicized* text indicates the strategy is mapped on the master plan in diagrams at the end of this section)

- Formally sign on to the American College and University Presidents’ Climate Commitment (ACUPCC) – determine net neutrality date and designate committee to work on climate action plan.
- Develop a written Energy Conservation Plan for the LSU flagship campus, detailing strategies and a schedule for reducing energy in buildings
- Conduct at least an ASHRAE level 1 audit for all existing buildings greater than 25,000 square feet, use to develop targeted lists for efficiency upgrades, to be coordinated with the 2017 Sightlines portfolio report.
- Develop an outreach/education program targeting energy use reduction among staff, faculty, and students

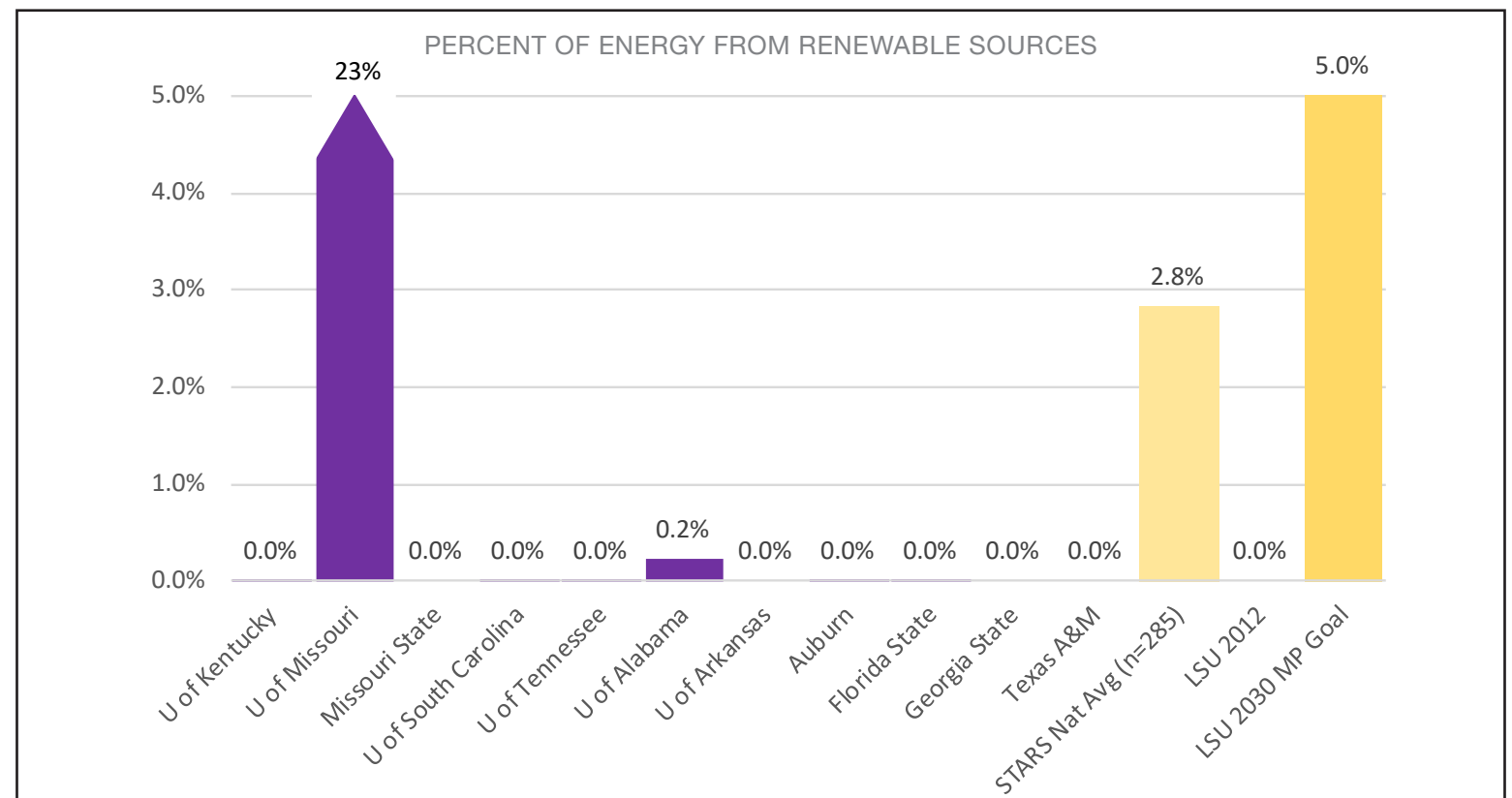
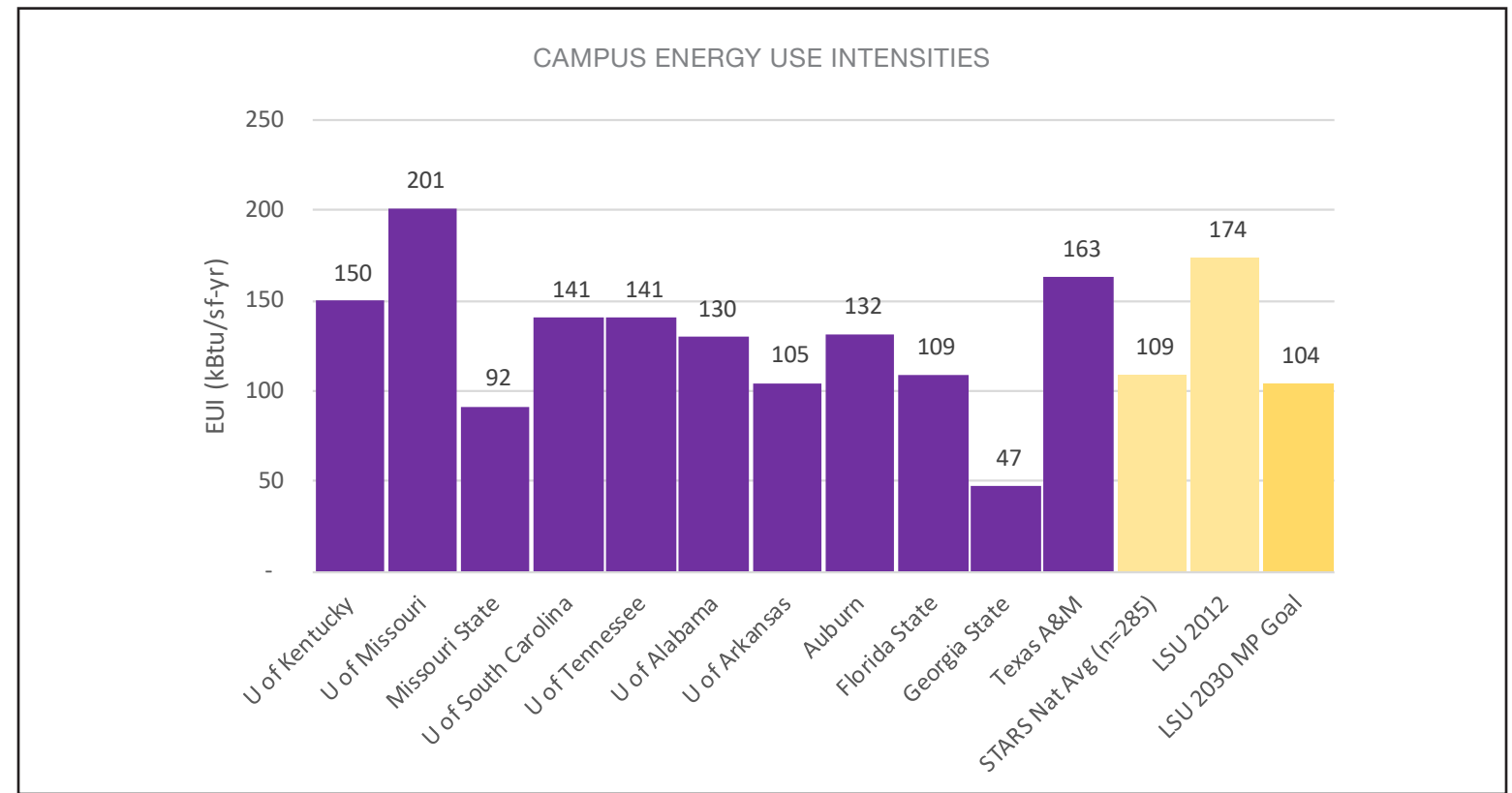

Source for both graphs: Benchmarking data was aggregated from the AASHE STARS website, where every participating University’s certified score is available to view credit by credit (<https://stars.aashe.org/institutions/participants-and-reports/>).

DESIGN GUIDELINES

SUSTAINABILITY**ENERGY EFFICIENCY AND GREEN BUILDING**

STRATEGIES CONTINUED

- Use the ENERGY STAR Portfolio Manager software to track energy usage in campus buildings, automate meter reading through submetering and building automation systems where possible.
- Install submetering on high priority campus buildings.
- Conduct at least one energy efficiency competition utilizing benchmarking every year.
- *Install a public energy dashboard online and in a prominent public lobby.*
- Achieve the ENERGY STAR certification for buildings for at least 3 office buildings on campus by 2025
- *Install solar photovoltaic and thermal systems on the LSU campus to offset conventional electricity usage*
- *Install a green roof on at least one building by 2020 to lower cooling costs and decrease stormwater runoff from the building footprint*
- *Meet minimum sustainability requirements for all major capital projects (>5,000 square feet) based on LSU Performance Goals. Meet aspirational requirements for any project identified as a “sustainability feature” project (refer to section X for detailed requirements).*
- *Establish a green labs program which encourages best practices for energy conservation in laboratories*
- Implement a university-wide IT energy conservation program
- Consider creative funding strategies for energy efficiency projects, using Harvard’s Green Campus Loan Fund as an example.
- *Explore biomass opportunities combined with sustainable forestry management as a renewable energy source*



HILL TOP ARBORETUM



CYPRESS HALL

DESIGN GUIDELINES

SUSTAINABILITY

TRANSPORTATION

Creating a more sustainable transportation network throughout LSU’s campus fosters both a more vibrant campus while drastically reducing greenhouse gas emissions associated with travel into and around campus. Transportation touches many aspects of sustainability, but none may be as important as how a bikeable and walkable campus increases student health through the promotion of an active campus lifestyle.

GOALS FOR 2030:

- **25% of institution’s fleet** non-purely fossil-fuel based
- **90% of students** use sustainable commuting options
- **50% of faculty** use sustainable commuting options

STRATEGIES (*italicized* text indicates the strategy is mapped on the master plan in diagrams at the end of this section):

- Continue efforts (e.g. Easy Streets Phase II) to become a more pedestrian-oriented campus and provide safe travel for bicyclists and pedestrians
- Improve bicycle facilities, including the expansion of bike lanes and routes on campus
- Promote awareness among the University community of the environmental, human health, and economic impacts of transportation choices
- Install covered bike storage and shower facilities in new buildings
- Enhance historic core pedestrian experience through adding a “Dismount” signage and bike rack parking along perimeter.
- Support and promote bike sharing efforts and programs
- Ensure short term bicycle parking (racks) within 50 feet of all occupied, non-residential buildings. Ensure long term bicycle storage available within 330 feet of all residence halls.

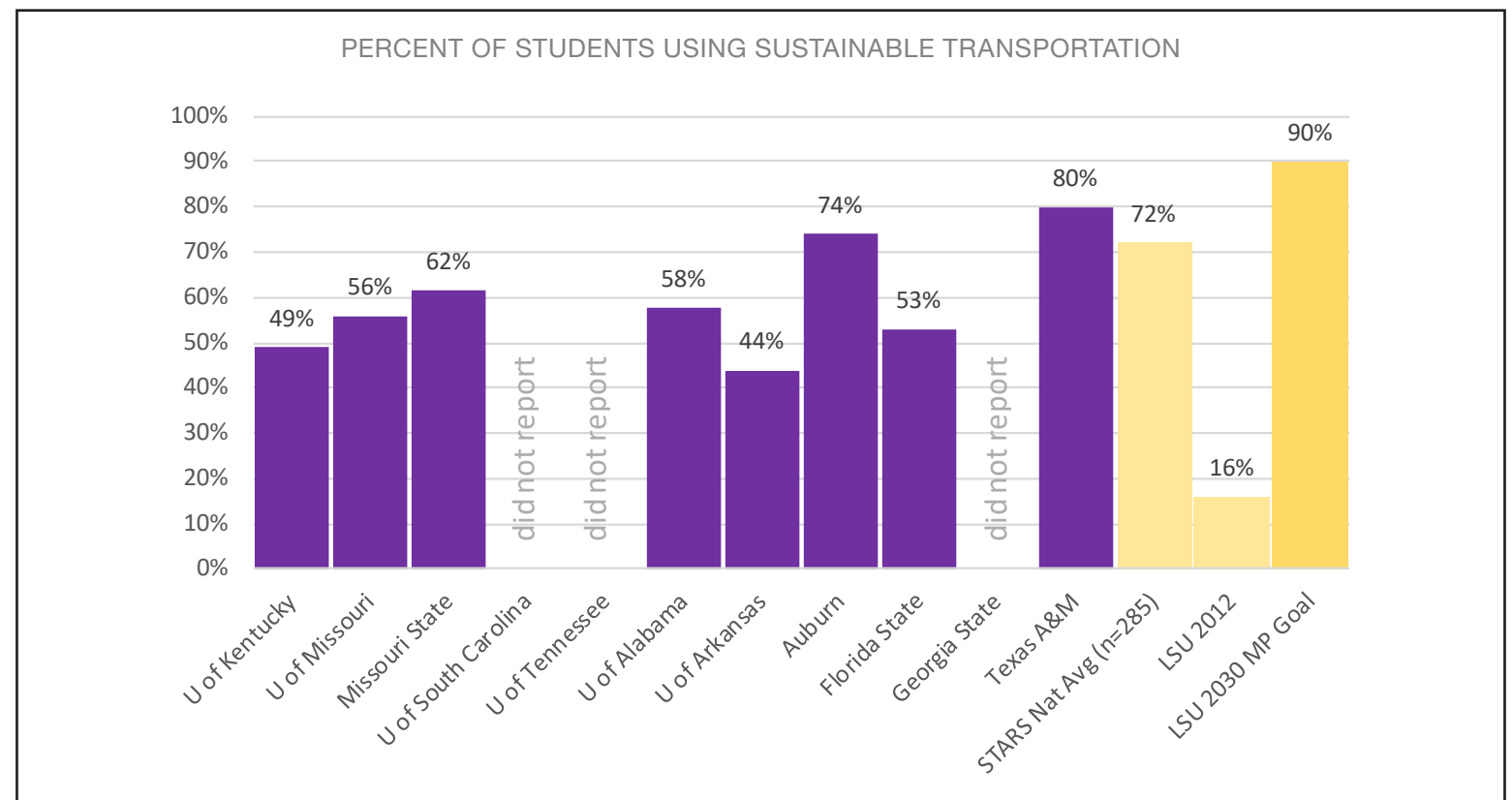
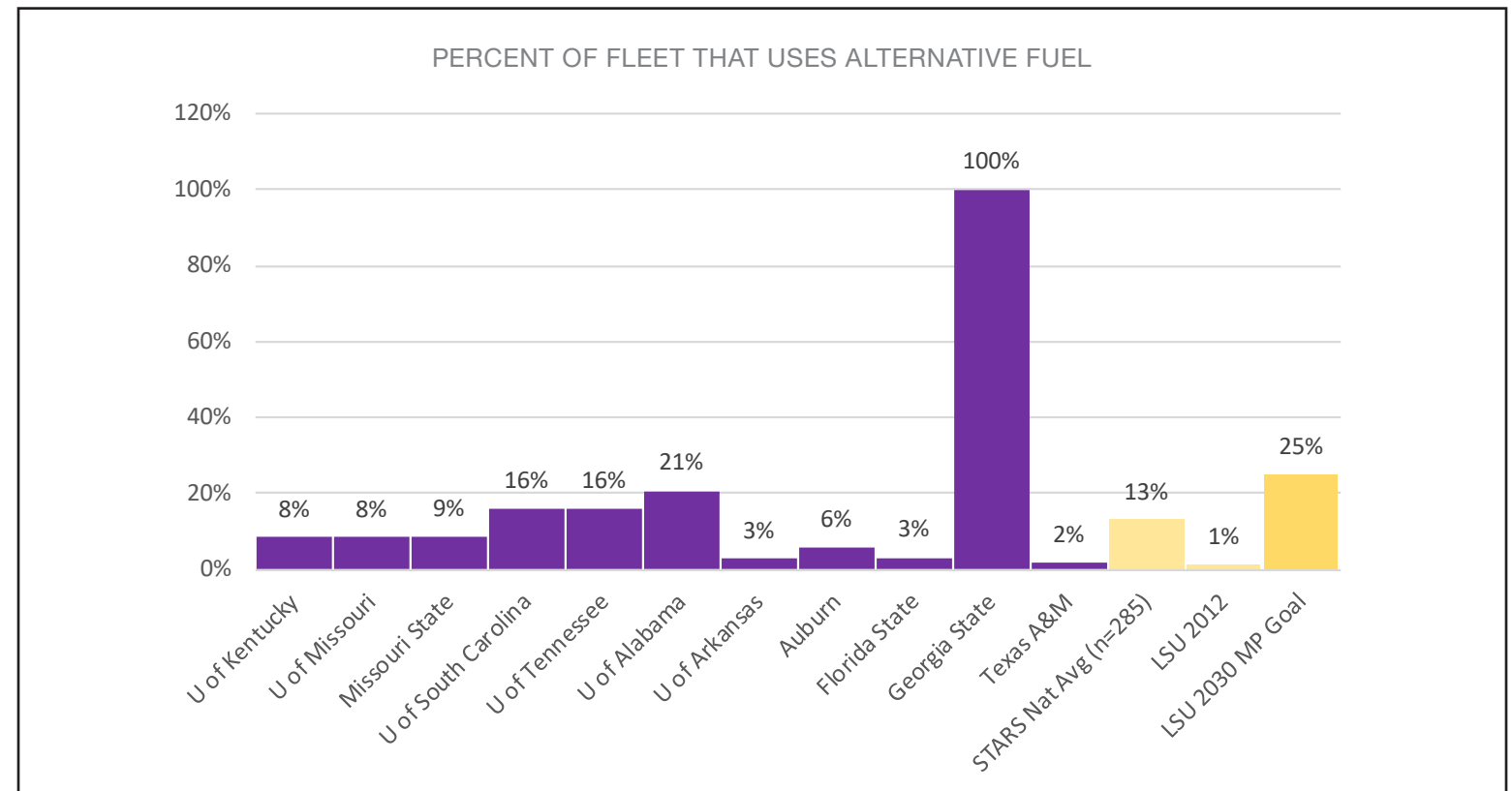

Source for both graphs: Benchmarking data was aggregated from the AASHE STARS website, where every participating University’s certified score is available to view credit by credit (<https://stars.aashe.org/institutions/participants-and-reports/>).

DESIGN GUIDELINES

SUSTAINABILITY

TRANSPORTATION

STRATEGIES CONTINUED:

- Achieve Bicycle Friendly University status from the League of American Bicyclists
- Decrease the prevalence of single occupancy vehicles on campus through enhanced alternative transportation infrastructure, programs and incentives
- Expand on existing car and rideshare programs available to campus (Geaux Ride, ZipCar)
- Continue to promote the existing electrical vehicle charging stations on campus, and acquire new stations as the number of users grows
- Procure electric vehicles for university fleet
- Continue to switch Tiger Trails fleet to low sulfur diesel and greener technology
- Celebrate National Bike Month annually through campus events or competitions
- Formally track bicycle usage on campus
- Conduct a transportation satisfaction survey with students, faculty and staff
- Increase ratio of bicycle parking to campus population
- Develop a theft prevention program for bicycles
- Promote bicycle safety by offering classes or seminars
- Partner with Bike Baton Rouge to promote bicycling locally and on campus
- Consider financial incentive programs to encourage bicycle use
- Develop alternative transportation education programs for targeted groups on campus
- Involve faculty in bicycle education
- Convert unnecessary parking lots into pedestrian amenities and open green space.

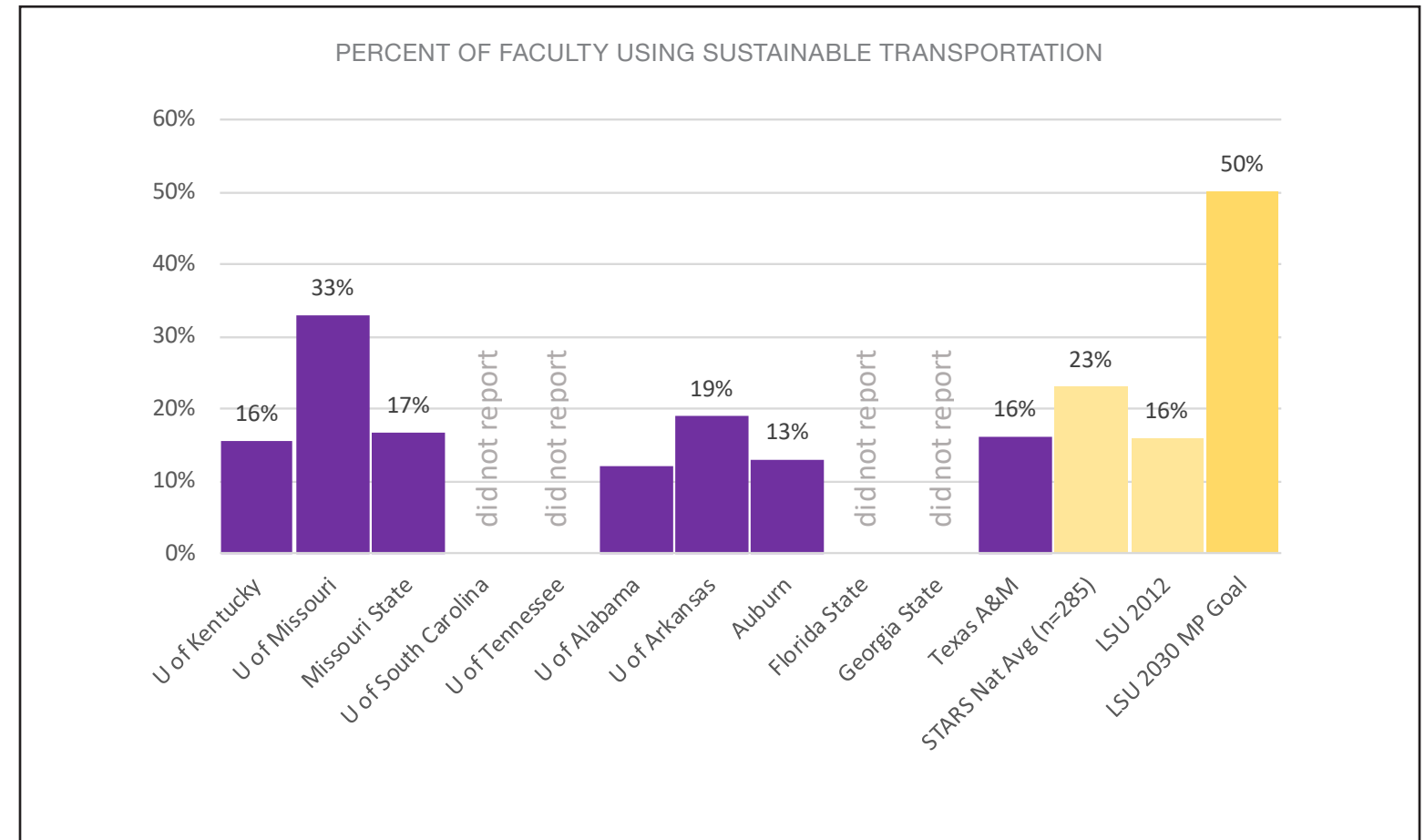

Source: Benchmarking data was aggregated from the AASHE STARS website, where every participating University's certified score is available to view credit by credit (<https://stars.aashe.org/institutions/participants-and-reports/>).

DESIGN GUIDELINES

SUSTAINABILITY

WASTE REDUCTION AND RECYCLING

LSU is already a leader amongst its peers when it comes to waste diversion and construction recycling. It also is building a robust track record of integrating recycling into the culture of the university as evinced by the second year in a row the university led the nation in the Game Day Recycling Challenge.

GOALS FOR 2030:

- **75% of waste diverted** (recycled, reused, etc.) from the landfill or incinerator.
- **90% of construction and demolition materials** recycled, donated, or otherwise recovered.

STRATEGIES (*italicized* text indicates the strategy is mapped on the master plan in diagrams at the end of this section):

- Continue annual Litteratti campaign to reduce waste and increase recycling on campus
- Recycle at least 90% of all construction and demolition waste from projects
- Develop a campus-wide waste reduction policy, including a comprehensive materials management strategy
- Quantify carbon impacts associated with the LSU campus waste stream in order to identify opportunities to better manage waste and reduce emissions.
- Develop a composting pilot program for Dining Operations. Eventually expand this into other areas such as residence halls
- Develop strategies for improving management of university materials and identify opportunities to utilize recovered materials as inputs for local and non-profit ventures (e.g. a Chuck it for Charity program for Move in/Move out)
- Expand the number of BigBelly solar units on campus

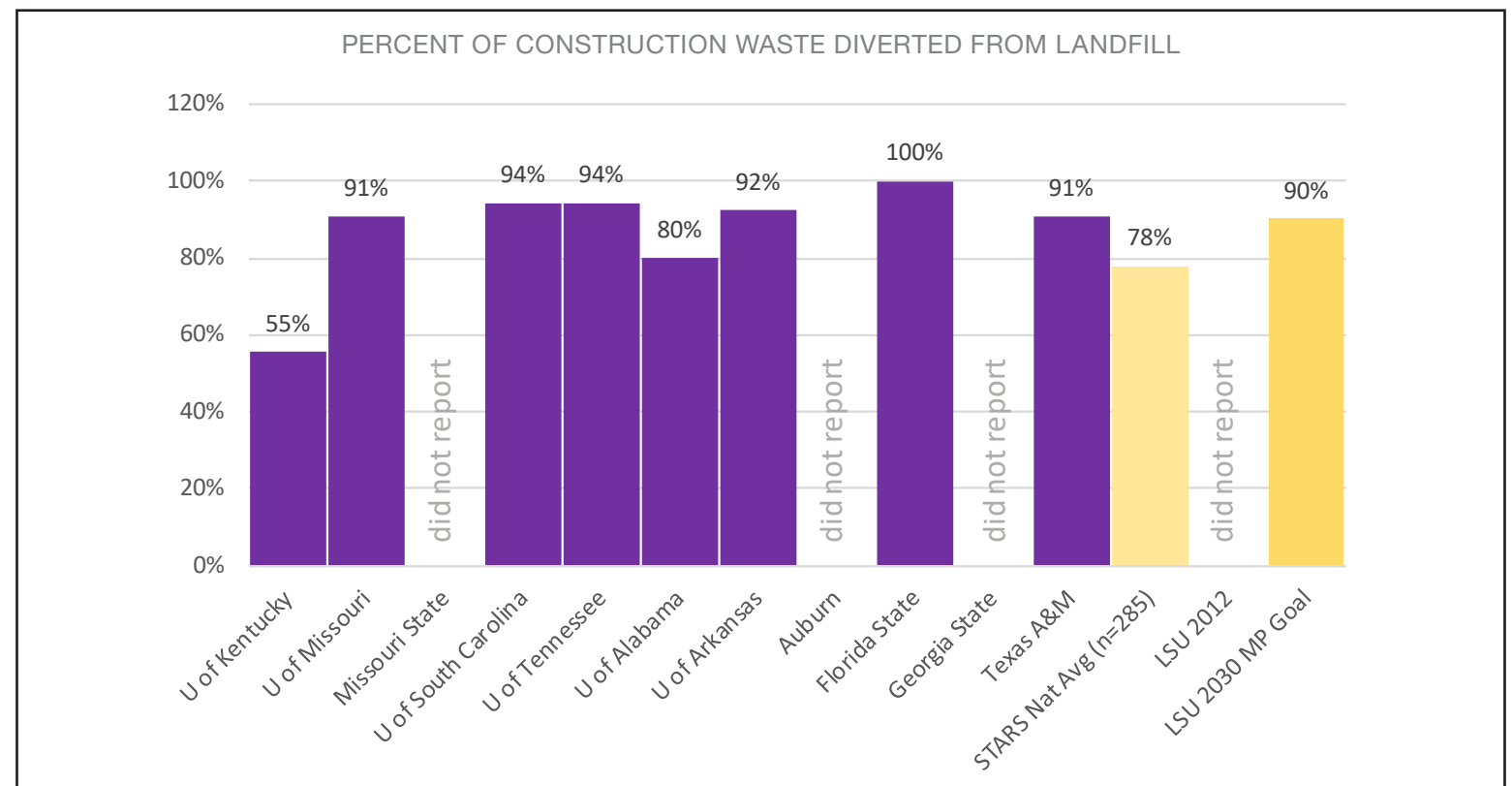
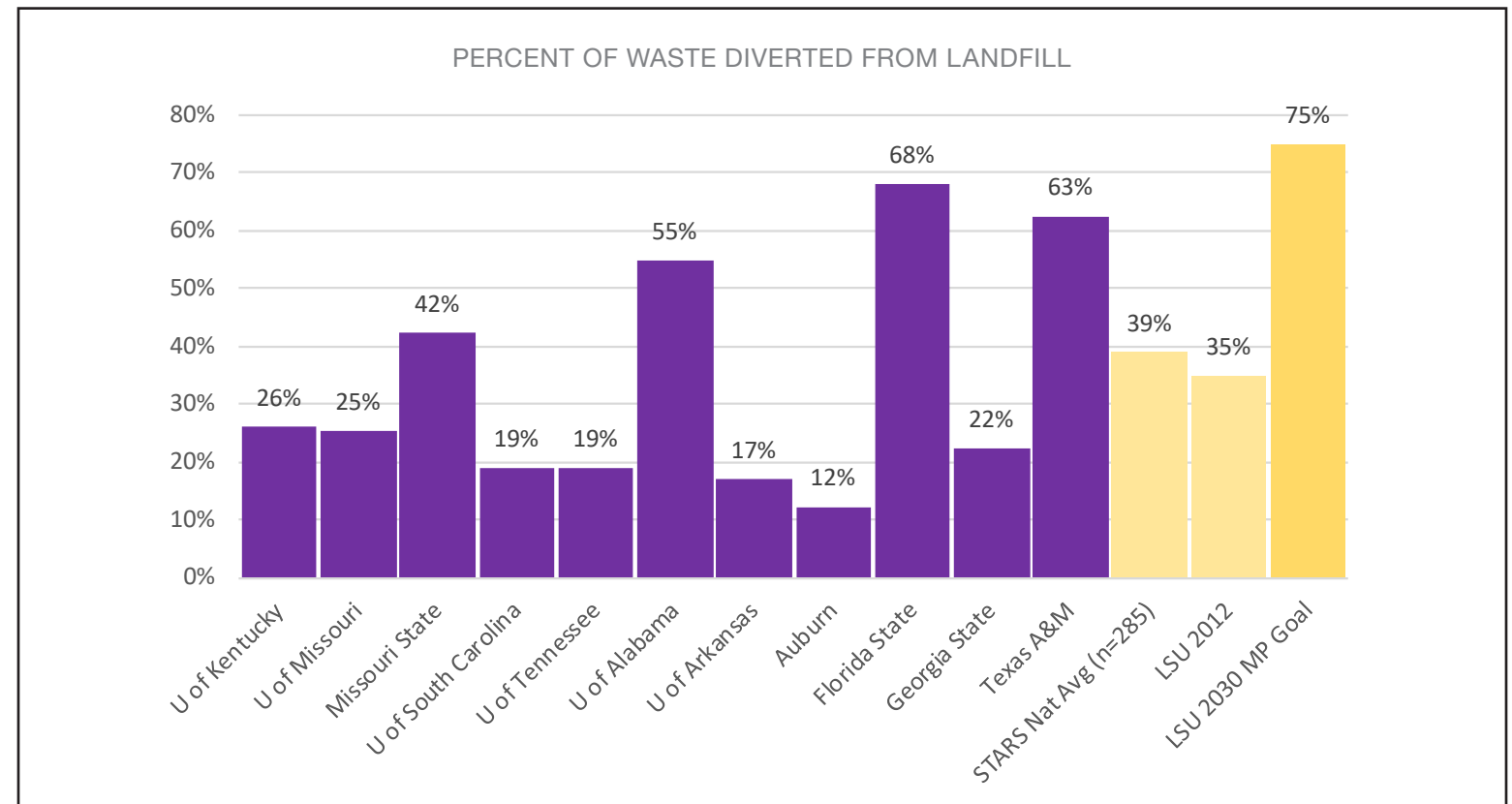

Source for both graphs: Benchmarking data was aggregated from the AASHE STARS website, where every participating University's certified score is available to view credit by credit (<https://stars.aashe.org/institutions/participants-and-reports/>).

DESIGN GUIDELINES

SUSTAINABILITY

WASTE REDUCTION AND RECYCLING

STRATEGIES CONTINUED:

- Continue to identify strategies for decreasing waste sent to the landfill as part of game day (football, basketball and baseball) operations
- Continue participating in the GameDay Recycling Challenge each year
- Implement a program that diverts reusable furniture to needy charities during move-in and move-out days.
- Apply for and receive grants for waste reduction, recycling, sustainability education and awareness programs, and campus beautification.



GAMEDAY RECYCLING CHALLENGE

DESIGN GUIDELINES

SUSTAINABILITY

PROCUREMENT

Universities are large purchasers of goods and services, which makes them catalysts for change when it comes to choosing which products to buy in terms of food, cleaning products, and services from the community. These choices have the potential to reinforce key values around sustainability while having substantive impacts on local, regional, and national economies.

GOALS FOR 2030:

- **25% of total purchases** from disadvantaged businesses, social enterprises, and/or local community-based businesses
- **25% of expenditures on cleaning** and janitorial products that are 3rd party verified to be healthy and sustainable (2012 AASHE Report for LSU = 9.5%)

STRATEGIES (*italicized* text indicates the strategy is mapped on the master plan in diagrams at the end of this section):

- Develop University-wide standards for targeted environmentally preferred products by 2019
- Procure commodities that are certified to meet sustainability standards in the areas of paper, electronics, cleaners, lab products, energy and vehicles:
 - Paper and Forest Products:
 - Forest Stewardship Council www.fsc.org
 - Chlorine Free Products Association www.chlorinefreeproducts.org
 - Electronics and Appliances:
 - Continue purchase of Energy Star certified products www.energystar.gov/ purchasing
 - Electronic Product Environmental Assessment Tool (EPEAT) - www.epeat.net

- Green Cleaners and Lab Products:
 - Environmental Choice www.environmentalchoice.com
 - Green Guard www.greenguard.org
 - Green Seal www.greenseal.org
 - Scientific Certification Systems www.scs-certified.com
- Renewable Energy:
 - Green-e www.green-e.org
- Vehicles
 - Federal Fuel Economy Summary www.fueleconomy.gov
- Reduce waste at point of purchase. Procure recycled content paper, recycled toner cartridges, and items that can be remanufactured, recycled or composted
- Purchase durable and reusable goods
- Use life-cycle cost analysis, rather than automatically choosing goods with the lowest purchase price
- Consider durability and reparability of products prior to purchase
- Invest in goods with extended warranties
- Conduct routine maintenance on products/equipment
- Continue to require ENERGY STAR certified appliances and equipment
- When possible, purchase goods in bulk or concentrated form
- Manage surplus effectively by eliminating excess purchases, reviewing past needs to minimize procurement of unneeded items, and periodically ensuring offices clean out supply cabinets prior to placing new orders
- Ensure all Departments are educated on the resources of both the LSU Surplus Department and the Campus Sustainability office for reuse and recycling of old/unneeded items and equipment

DESIGN GUIDELINES

SUSTAINABILITY

PROCUREMENT



BARNES AND NOBLE BOOKSTORE

DESIGN GUIDELINES

SUSTAINABILITY

LANDSCAPE AND GROUNDS

Sustainable stewardship of LSU’s landscape lies at the intersection of many critical issues to the university. Innovative application of green infrastructure helps mitigate flooding and protect Louisiana’s water quality. Incorporation of the latest water conservation strategies and increasing the use of recycled water on campus reduces cost while minimizing environmental impact. Using these principles to maintain and foster Louisiana’s landscape helps to sustainably preserve the legacy of LSU’s unique and beautiful campus.

GOALS FOR 2030:

- **30% reduction of total water use** per student
- **90% of campus grounds managed sustainably**, organically, or 3rd party certified/protected (70% in 2015 according to Princeton Review Rankings for LSU)
- **5% of water demands met by recycled/reused sources** (5% average for universities that report data in AASHE)
- **50% reduction** of total square footage of pervious surfaces

STRATEGIES (*italicized* text indicates the strategy is mapped on the master plan in diagrams at the end of this section):

- Maximize the use of locally sourced, native plant material that is well suited for the southeastern Louisiana environment. Such plant material will require less fertilizer, irrigation, and pesticide. Emphasis should be placed upon hardy perennials and shrubs rather than annuals
- Utilize the widest genetic base among individual species

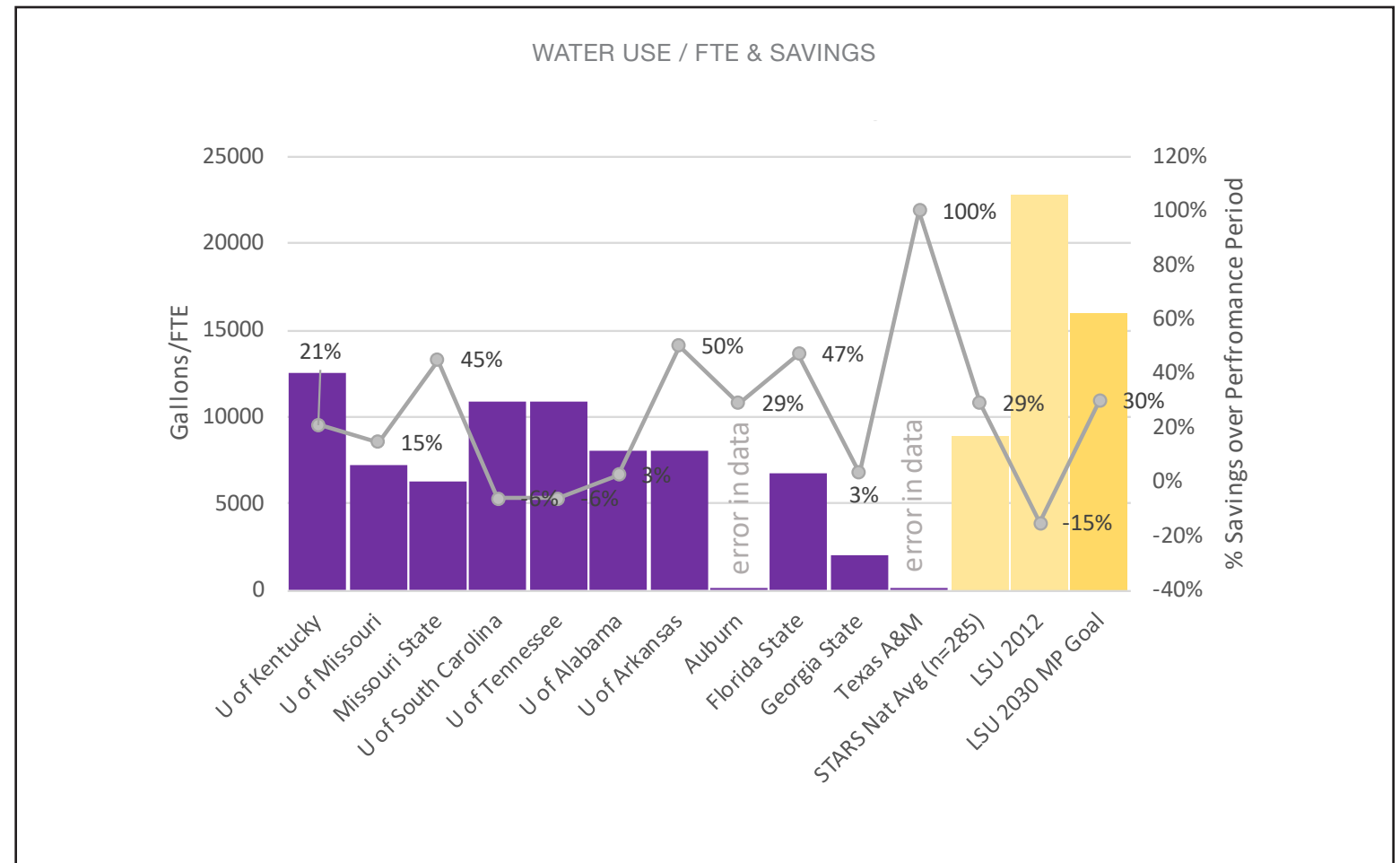

Source: Benchmarking data was aggregated from the AASHE STARS website, where every participating University’s certified score is available to view credit by credit (<https://stars.aashe.org/institutions/participants-and-reports/>).

DESIGN GUIDELINES

SUSTAINABILITY**LANDSCAPE AND GROUNDS**

STRATEGIES CONTINUED:

- Eliminate existing invasive exotic species
- Include endangered, rare species to the extent possible
- Include useful plants (e.g., pest deterrents, nitrogen-fixing plants, edibles and medicinals) for pedagogical and practical purposes
- Reduce high maintenance turf areas and monocultures where possible in favor of diverse native ground covers, tree canopies, prairies, understory trees and shrubs.
- *Integrate stormwater best management practices (BMPs) into social amenities, transportation infrastructure, and buildings to capture and treat stormwater*
- Maintain and update the campus tree inventory on an annual basis.
- Continue to participate in Tree Campus U.S.A. program
- *Work with faculty, students and staff to create a shared LSU Community Garden*
- *Dedicate a portion of campus to fruit and vegetable production*
- *Create or enhance wildlife habitat locations on campus*
- Create signage that provides students, staff, and visitors with opportunities to learn about native plant species (uses, functions, details, etc.), as well as planting purposes
- Reduce the quantity and impact of harmful, chemical based, landscaping maintenance products and techniques
- Use organic fertilizers to the maximum extent possible. Landscape Services already owns equipment necessary to make compost tea organic fertilizer
- Incorporate integrated pest management practices to deal with seasonal pests
- Work to minimize or eliminate toxic chemicals from landscape management
- Continue to work with the LSU Foundation to promote and manage the Endow an Oak program
- *Install cisterns for capturing rainwater and reusing on landscape beds*



ABOVE: INDIAN MOUNDS, BELOW: HISTORIC QUAD

DESIGN GUIDELINES

SUSTAINABILITY

FOOD

Food has always had a place at the table when it comes to sustainability. What we eat, how we treat the animals that provide us food, who we purchase food from, where it comes from, and how we dispose of food waste all have substantial health and environmental impacts. In 2015 the Princeton Review recognized LSU for purchasing 44% of all its food from local vendors, and through 2030 LSU aims to increase this number drastically and attain similar performance for purchasing sustainably produced animal products.

GOALS FOR 2030:

- **75% of dining services** food and beverage expenditures that are local and community-based (3% in 2015 according to Princeton Review Rankings for LSU)
- **25% of total dining services and food purchases** comprised of sustainably produced animal products

STRATEGIES (*italicized* text indicates the strategy is mapped on the master plan in diagrams at the end of this section):

- Work with Faculty on developing a Sustainable Agriculture/Food Systems Minor and Major
- Continue to expand edible landscape program, such as Student Government satsuma tree groves
- Develop a campus composting program (see Waste Reduction & Recycling section)
- Work with faculty, students and Student Government to develop a campus farm for purposes of teaching and research
- Phase out Styrofoam use on campus
- Consider establishing a Campus Farmer’s Market from food grown on campus

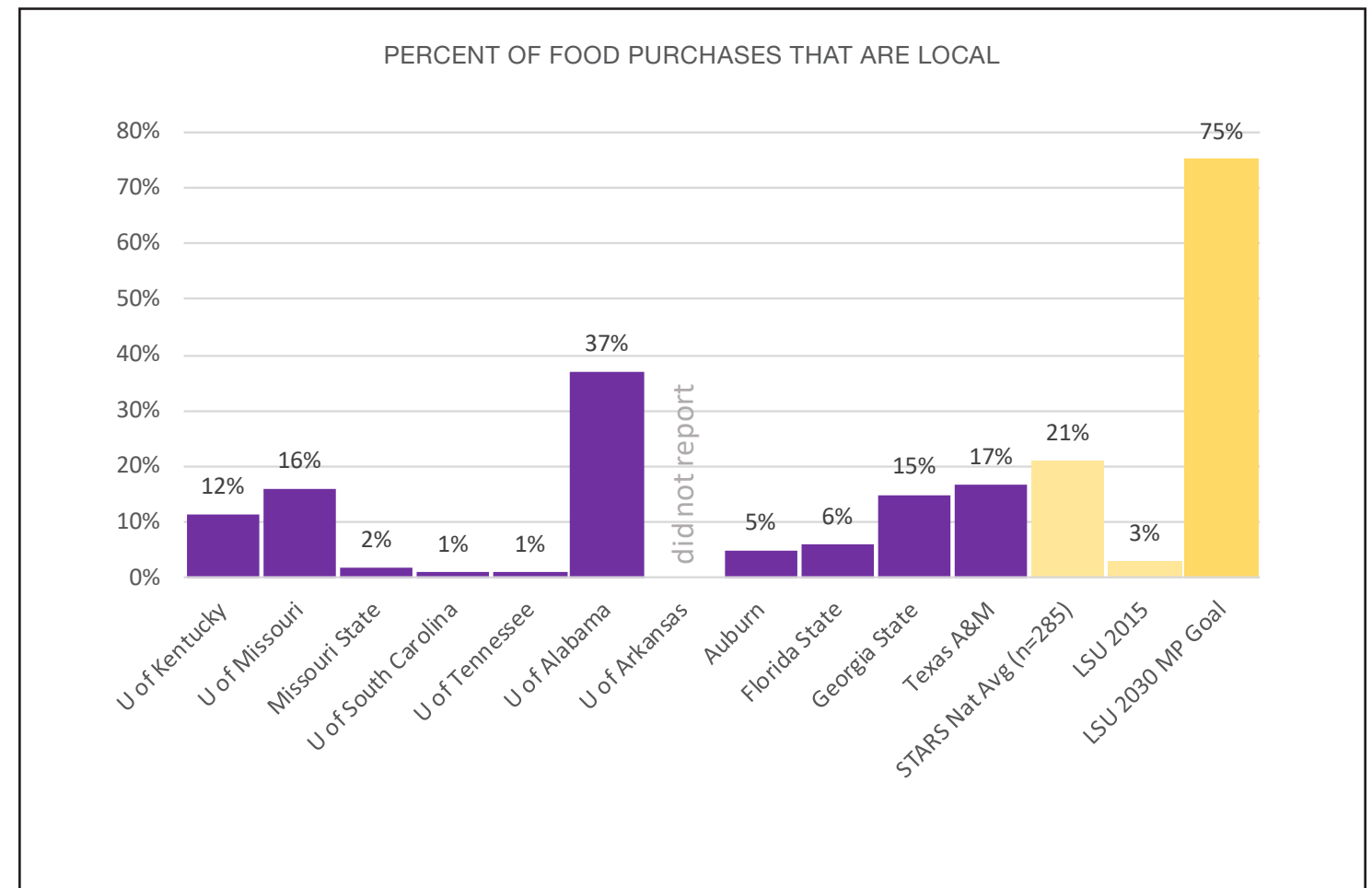

Source: Benchmarking data was aggregated from the AASHE STARS website, where every participating University’s certified score is available to view credit by credit (<https://stars.aashe.org/institutions/participants-and-reports/>).

DESIGN GUIDELINES

SUSTAINABILITY

FOOD

STRATEGIES CONTINUED:

- Continue to formally partner with the Sustainable Agriculture program in the College of Agriculture, including promotion and funding of the student-run Hill Farm Farmer's Market
- Expand the "trayless" dining program by converting all dining halls to a plate- only dining experience. Market to both current and prospective students the sustainable choice of this program
- Promote "Refills Not Landfills" Campus Sustainability program (in conjunction with grant from Keep Louisiana Beautiful) past the grant period to encourage campus community to reuse containers
- Provide discounts to patrons who use reusable bottles and containers
- Revamp to-go boxes with durable plastic containers that can be returned for cleaning in exchange for tokens, payment, etc.



DESIGN GUIDELINES

SUSTAINABILITY

FOOD

Campus Committee For Sustainability
Strategies Map

LANDSCAPE, GROUNDS, FOOD

-  parking lot retrofits - reduce pervious cover, add plantings
-  new buildings from the master plan
-  major stormwater feature
-  bioswales integrated into streetscape
-  parking lot conversions - pedestrian focused plaza space
-  current farmers market event location
-  potential farmers market locations in new master plan
-  edible landscape possibilities (satsuma groves in parking lots, or more natural plantings on campus)
-  community garden possible locations
-  good sites for educational kiosks about landscape
-  potential cistern locations for landscape irrigation
-  potential for wildlife habitat enhancement
-  permeable paving integrated into transit mall
-  student government satsuma tree program



DESIGN GUIDELINES

SUSTAINABILITY

**ENERGY, WASTE
REDUX + RECYCLING**

Campus Committee For Sustainability
Strategies Map



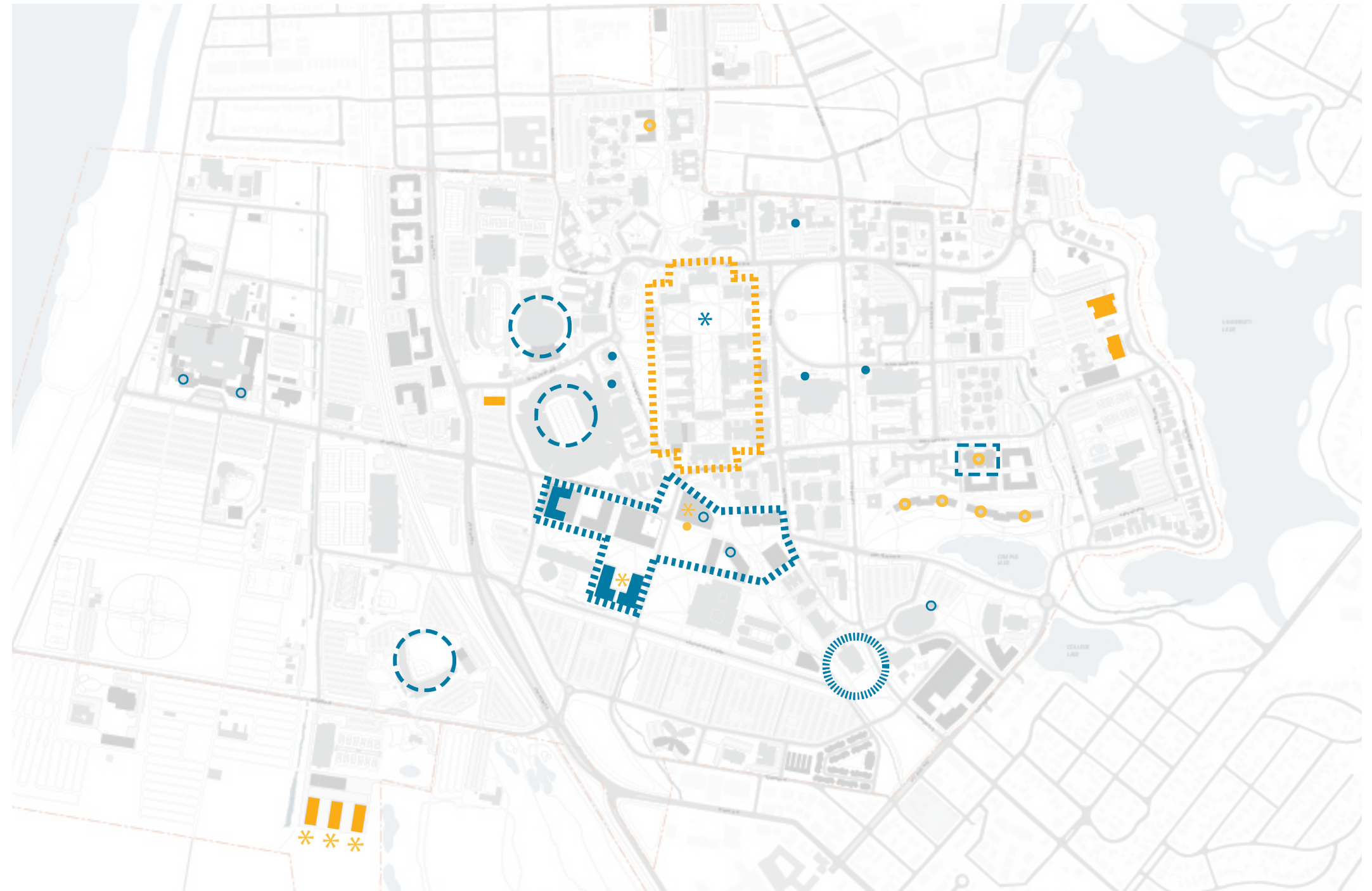











- potential/ EnergyStar office certification opportunities
- buildings with substantial lab components, good green lab program candidates
- buildings that can propel event-based recycling programs
- new construction zone, high priority for construction waste recycling
- historic core buildings are good candidates for energy audits
- current high profile Big Belly solar compactor locations
- public energy dashboard in prominent building area
- projects with high hot water demand are good options for solar hot water pilot projects
- potential biomass site next to Renewable Natural Resource building
- potential sites for greenroof due to elevation change or having visible roof planes
- potential composting site next to major dining hall
- ✱ demo site, prioritize re-use of building materials
- ✱ potential featured sustainability project



DESIGN GUIDELINES SUSTAINABILITY

TRANSPORTATION

Campus Committee For Sustainability
Strategies Map

-  pedestrian-only area, bike dismount zone
-  new buildings from the master plan
-  new bus routes
-  community transit routes
-  parking lot conversions - pedestrian focused plaza space
-  current farmers market event location
-  potential farmers market locations in new master plan
-  community transit connection points
-  new transit hub
-  current bike hubs
-  potential good locations for new bike hubs
-  current existing electric charging stations
-  potential good locations for new charging stations
-  added bike lanes
-  gated streets that close to help facilitate pedestrian movement

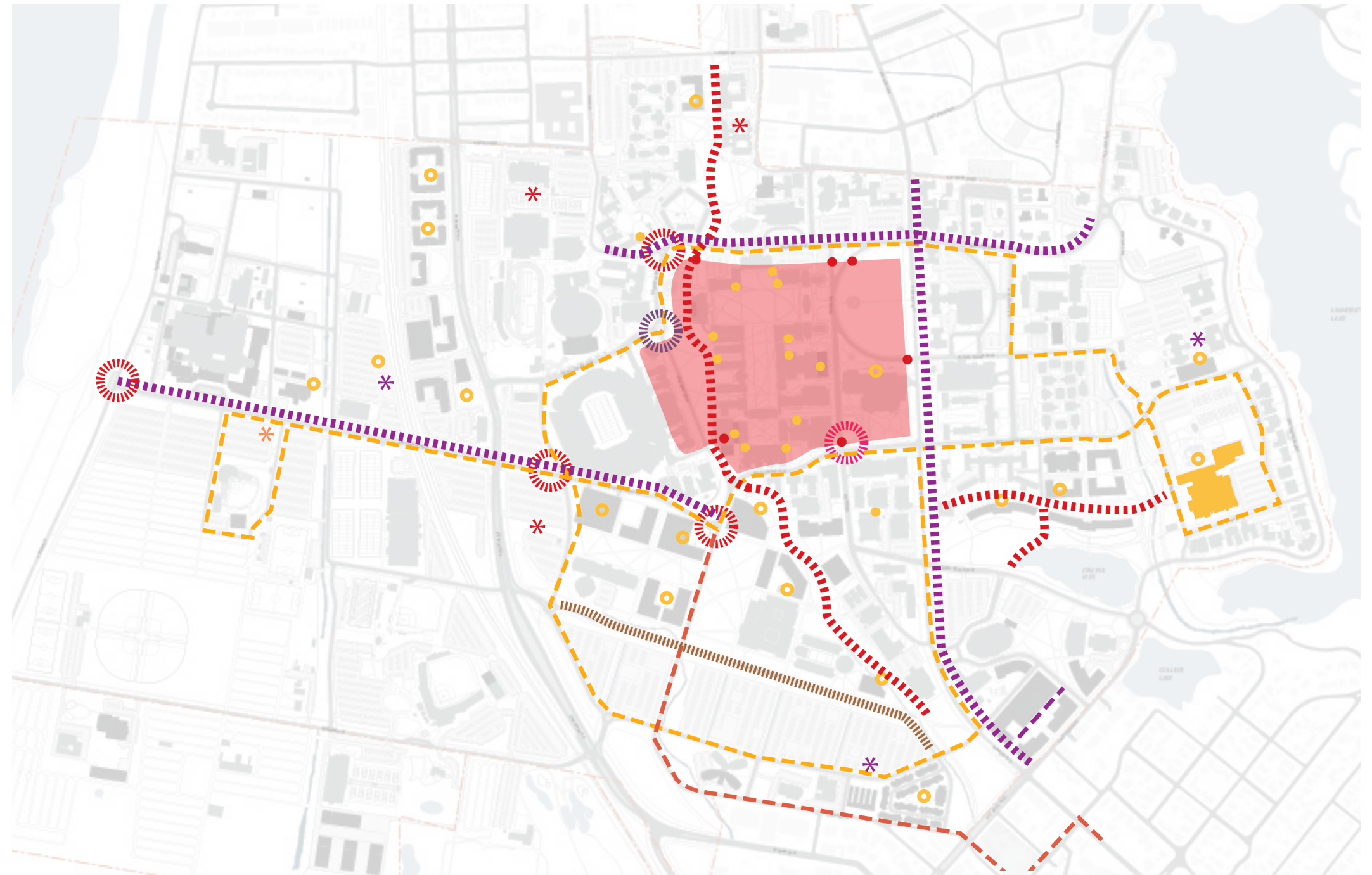

DESIGN GUIDELINES

1.6 GOVERNANCE

The intent of creating a governance structure for Capital Project Execution is to provide a process to ensure that capital projects are executed in alignment with the Master Plan framework and intent (as part of the “approved planning documents” per LSU Statement PS 23.10). The Design Guidelines document (refer Appendix) explains in further detail the intent of the various planning documents.

These approved planning documents, as seen in the figure to the right, provide varying levels of aspirational and prescriptive guidelines. The Master Plan provides the highest level aspirations for campus growth over the centuries and the Design Guidelines provide high level descriptions for how design can achieve those goals. The Site and Landscape Standards (refer to Appendix) and Facility Design Standards and Specifications documents provide more prescriptive requirements for architecture, landscape architecture, and engineering standards. For example, the Design Guidelines might encourage designers to create a building first floor which is public and showcases the activity within in order to create a vibrant campus, while, the Facility Design Standards & Specifications might specifically require use of transparent glass on the building facade.

The draft of Policy Statement 23.10 (PS 23) lays out the process for project approvals, including required submittals at each phase.

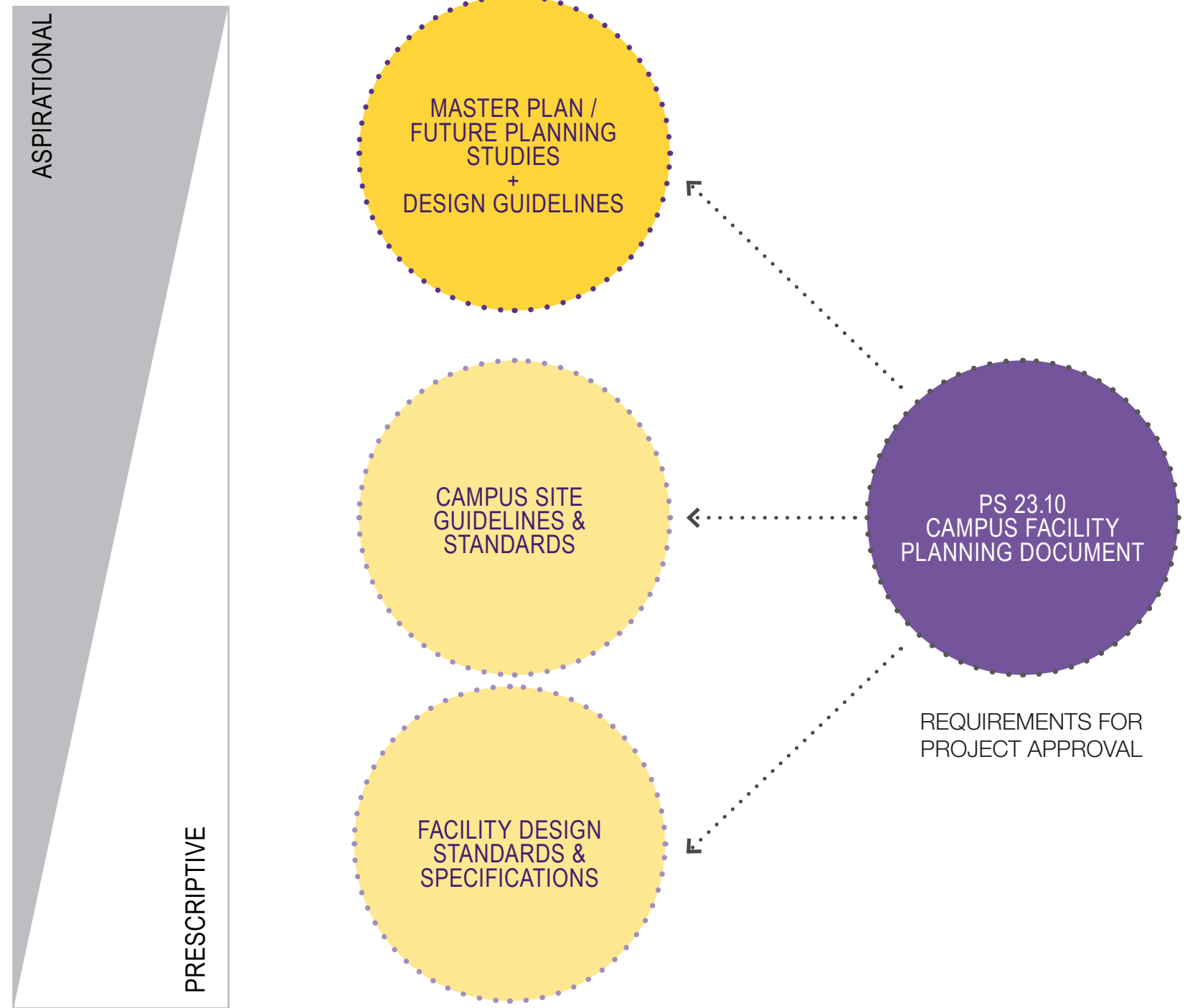

APPROVED PLANNING DOCUMENTS

DESIGN GUIDELINES GOVERNANCE

The key players in the approval process for new construction are shown at right. The Campus Planning and Oversight Committee (CPOC) (currently FDDC) is the main review body for new projects and includes representatives from LSU facilities team, departmental faculty, and various campus stakeholders where some members have voting power and some solely provide representation.

Other high-level university leadership who may review a project separately from the CPOC include the LSU Board of Supervisors (BOS), University President, Provost, and those shown in the yellow circles at right.

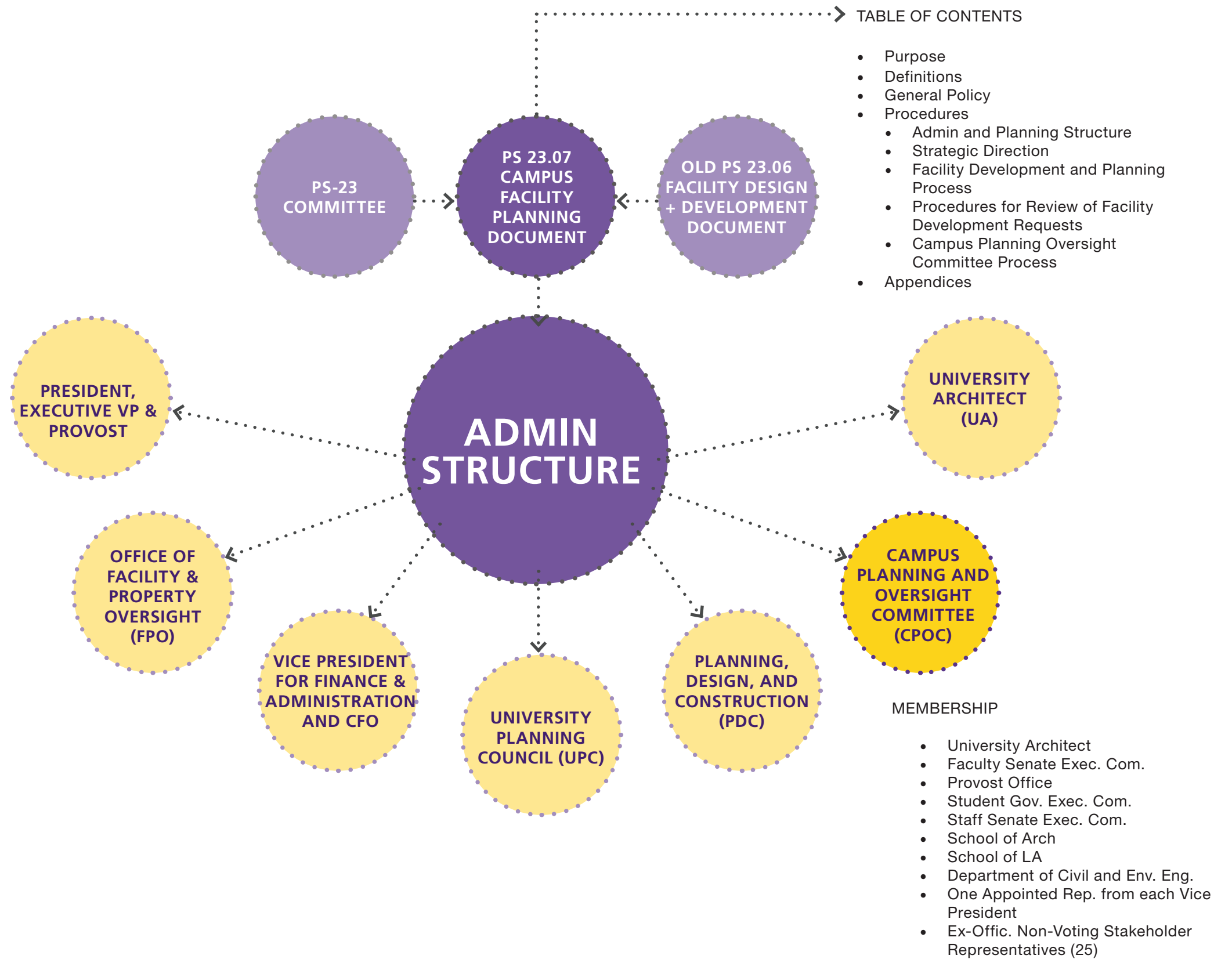

DESIGN GUIDELINES GOVERNANCE

The four broad steps in the project approval process are as follows:

OUTREACH - The University Architect (UA) and PDC lead a series of meetings to build consensus about how the project should respond to the design guidelines and goals of the Master Plan. These meetings include project stakeholders and high-level decision-makers should be present. Depending on the project's needs, outreach meetings can also solicit funding.

CONCEPT DEVELOPMENT - PDC analyzes and confirms a building site and orientation, building program, budget, and whether this building will be a sustainably-focused building, which requires a higher level of performance and adherence to design requirements. The UA develops a contextual analysis to establish the design intent and context for the project. The UA drafts a contextual design narration.

SCHEMATIC DESIGN - The UA works with designers and recommends a design to CPOC and the LSU BOS. The CPOC reviews a schematic building design, narrative about how the building responds to each principle of the Design Guidelines, a Sustainability Requirement Checklist, and a narrative of how the project meets sustainability requirements. If this project is a sustainability-focused building, the team will also review a narrative responding to the AIA COTE Top 10 framework and a narrative describing the feasibility of meeting a 3rd party certification standard: LEED, Living Building Challenge (full or petal certification), Sites, WELL, or other.

DESIGN DEVELOPMENT - BID / AWARD The final construction document completion is managed by PDC, with approval by UA and others to ensure project meets the intent approved by CPOC, high level leadership and the LSU BOS. The goal of this management is

to ensure that the design principles and sustainability requirements the team previously identified have been carried through into the construction documents.

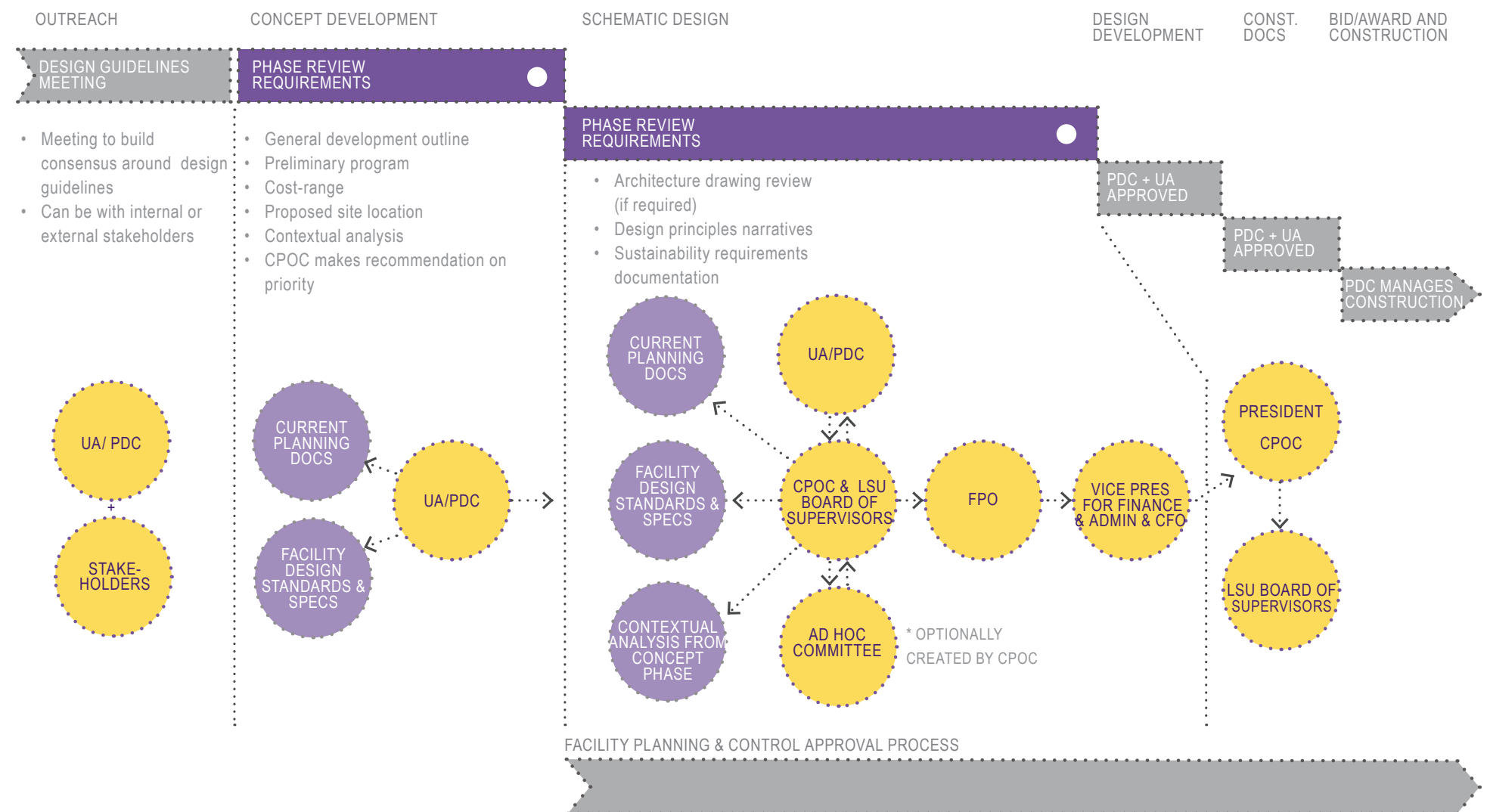

STEPS IN THE PROJECT DESIGN APPROVAL PROCESS